



specialty
fabricators

3PS



3PSNL Multi-Deck 90° Wedge Merchandiser

Applications:

- Cheese
- Deli
- Salad
- Sandwich
- Food Service
- Food Prep
- Beverage
- Grab-n-go

Features

- Exterior and interior of case is available in stainless steel or custom color.
- Customized exterior to fit store décor.
- Solid surface top sill.
- 1" and 3" cart guard bumpers.
- Adjustable (height) shelves w/ LED lighting and price tag molding. (3) Max.
- Plexiglas front flue
- Solar digital thermometer.
- Custom lengths and features available upon request.



Options:

- Remote Glycol Refrigerant
- Night curtain
- Fully customizable case line

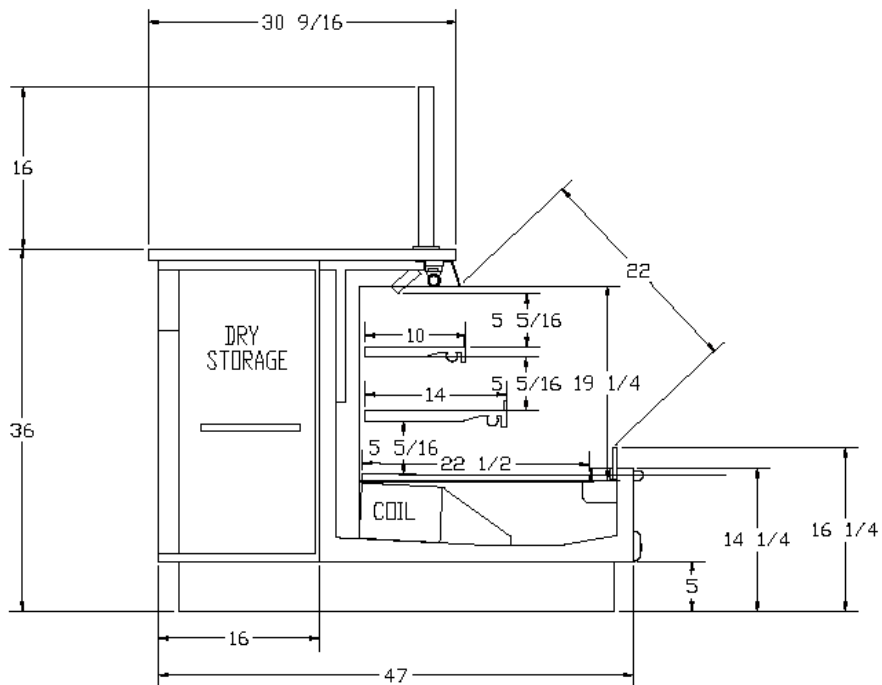

3PSNA-60 Vertical Merchandiser

Applications:

- Deli
- Dairy
- Soup
- Sandwich
- Beverage
- Grab-n-go

Features

- Available in 2', 3', 4', 5' and 6' lengths.
- Exterior and interior of case is available in stainless or custom color.
- Customized exterior to fit store décor.
- Drain pan designed for quick removal and easy cleaning.
- 2" wrap-around cart guard bumper.
- Adjustable (height/angle) shelves w/ LED lighting and price tag molding. (3) Max.
- Full-view ends.
- Plexiglas end glass
- Solar digital thermometer.
- Locking heavy duty concealed castors.
- 115V / 20A dedicated 6' cord w/plug.
- Custom lengths and features available.
- Remote Only

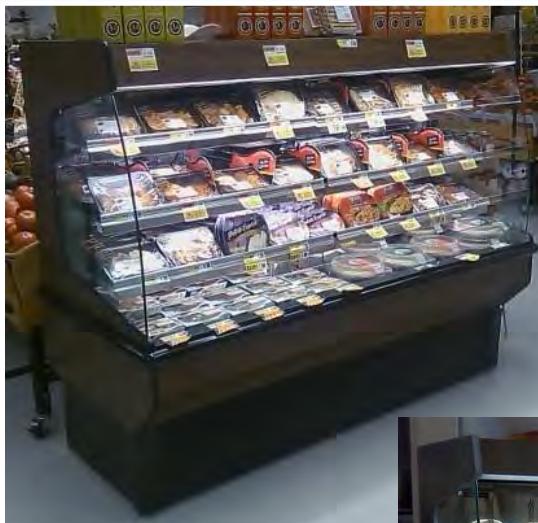

Options:

- Night curtain
- 12", 14", 16" shelves (lights optional)
- Solid or Extra Full-view end panels
- Tempered end glass

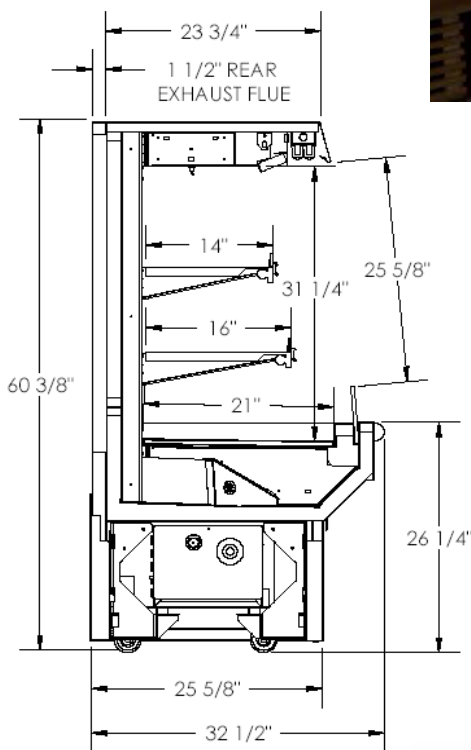

specialty
fabricators

118 meany road
wrightstown, nj 08562
www.specialtyfabricators.com
609-758-6995

3PSNA-68 Vertical Merchandiser

Applications:

- Deli
- Dairy
- Soup
- Sandwich
- Beverage
- Grab-n-go

Features

- Available in 2', 3', 4', 5' and 6' lengths.
- Exterior and interior of case is available in stainless or custom color.
- Customized exterior to fit store décor.
- 2" wrap-around cart guard bumper.
- Adjustable (height/angle) shelves w/ LED lighting and price tag molding. (3) Max.
- Full-view ends.
- Plexiglas end glass
- Solar digital thermometer.
- Locking heavy duty concealed castors.
- 115V / 20A dedicated 6' cord w/plug.
- Custom lengths and features available
- Remote Only

Options:

- Night curtain
- Case-top condenser hot air exhaust
- 12", 14", 16" shelves
- Solid or Extra Full-view end panels
- Tempered end glass

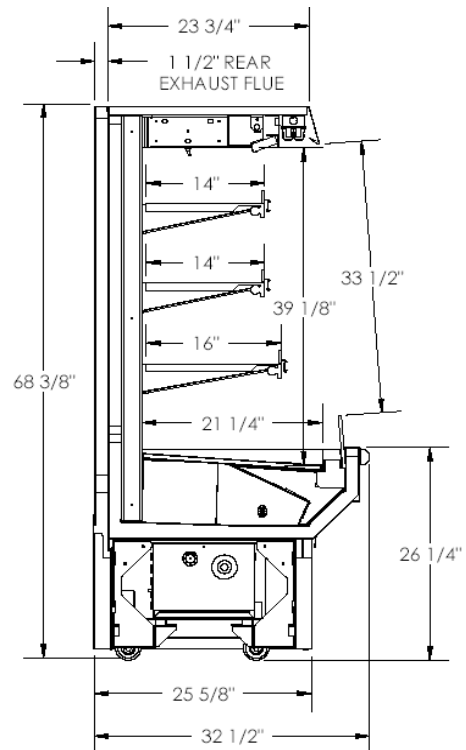

specialty
fabricators

118 meany road
wrightstown, nj 08562
www.specialtyfabricators.com
609-758-6995

3PS55-CC

Applications:

- Deli
- Dairy
- Sandwich
- Grab-n-go

Features

- Available in 2', 3', 4', 5' and 6' lengths.
- Exterior and interior of case is available in stainless or custom color.
- Customized exterior to fit store décor.
- 1" cart guard bumper.
- Adjustable (height/angle) shelves w/ LED lighting and price tag molding. (2) Max.
- Full-view ends.
- Plexiglas end glass
- Solar digital thermometer.
- Locking heavy duty castors.
- 115V / 20A dedicated 6' cord w/plug.
- Custom lengths and features available upon request.
- Remote Only



Options:

- Night curtain
- 12" & 14" shelving (lights optional)
- Solid contour end panels
- Tempered end glass

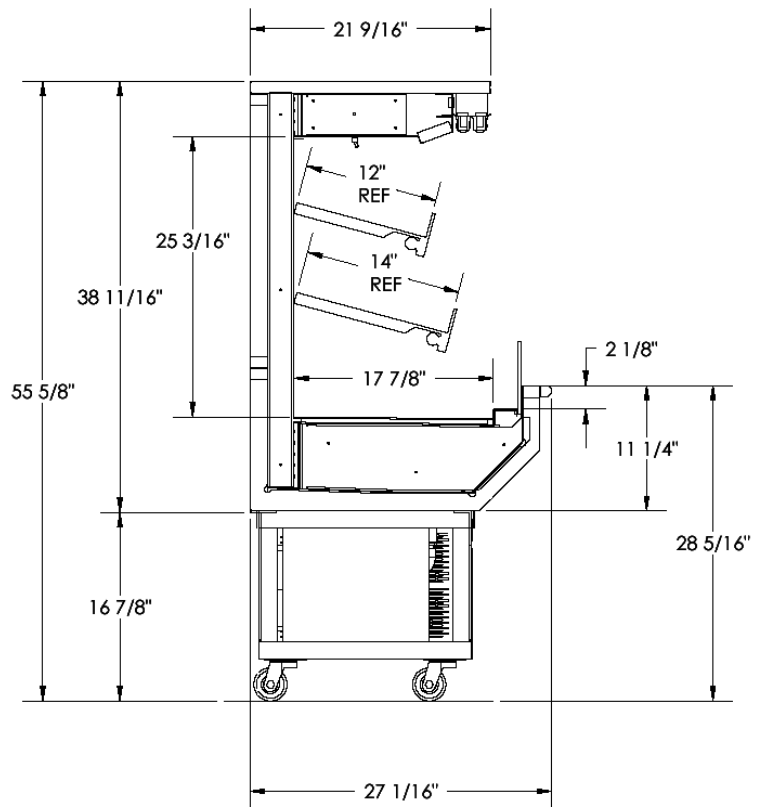

specialty
fabricators

118 meany road
wrightstown, nj 08562
www.specialtyfabricators.com
609-758-6995



specialty
fabricators

3PS Island



3PSCI Multi-Deck Center Island

Applications:

- Produce
- Deli
- Bakery
- Meals to Go
- Meat

Options:

- Remote Glycol Refrigerant available.
- Night curtain
- Expandable wire racks



Features

- Available in a variety of Lengths.
- Exterior and interior of case is available in stainless or custom color.
- Customized exterior to fit store décor.
- 1" and 3" wrap-around cart guard bumper.
- Adjustable (height) shelves w/ LED lighting and price tag molding. Max. 3 shelves
- Plexiglas front flue
- Solar digital thermometer.
- Custom lengths and features available.



Energy Efficiency
Compliant
DOE 2017



specialty
fabricators

118 meany road
wrightstown, nj 08562
www.specialtyfabricators.com
609-758-6995

3PSCI Multi-deck "School Bus" Island

LIGHTING SPECS					FANS SPECS		STANDARD		HI EFFICIENCY	
CASE	MAX#	ROWS	BULBS/ROW	120V	CASE	FANS#	120V	120V	120V	120V
EC	5		2	2.5A 300W	EC	2	.50A 60W	.26A	32W	
4'CI	10		1	2.5A 300W	4'CI	4	1A 120W	.52A	64W	
6'CI	10		2	5A 600W	6'CI	4	1A 120W	.52A	64W	
8'CI	10		2	5A 600W	8'CI	6	1.5A 180W	.78A	96W	
10'CI	10		3	7.5A 900W	10'CI	6	1.5A 180W	.78A	96W	
12'CI	10		3	7.5A 900W	12'CI	10	2.5A 300W	1.30A	160W	

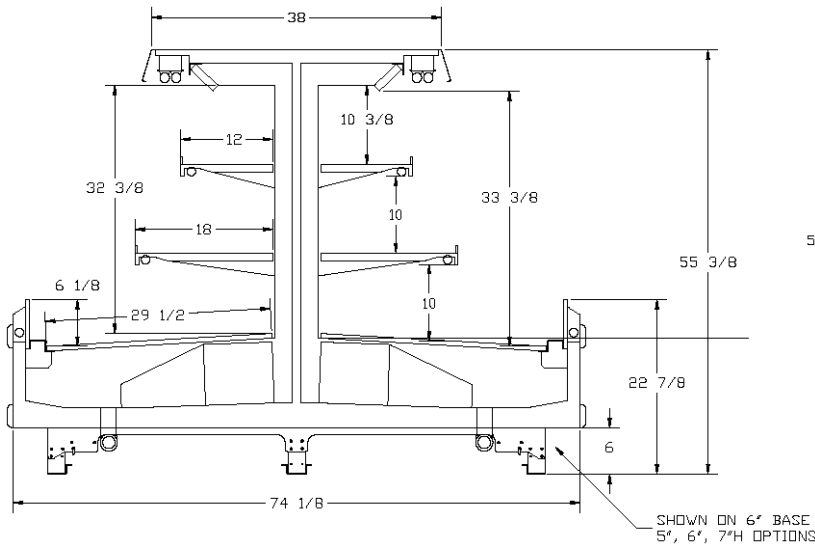

CENTER ISLAND CROSS-SECTION

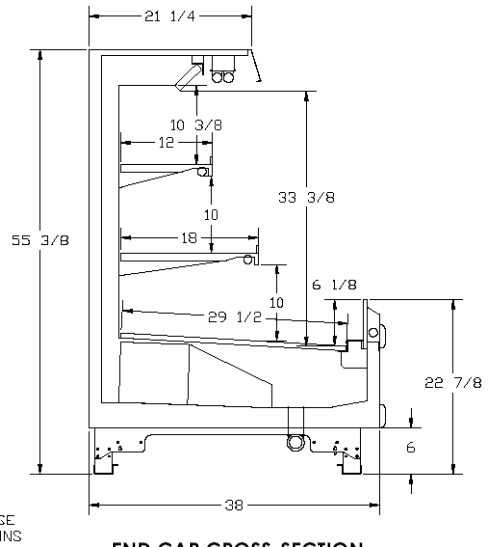

END CAP CROSS-SECTION

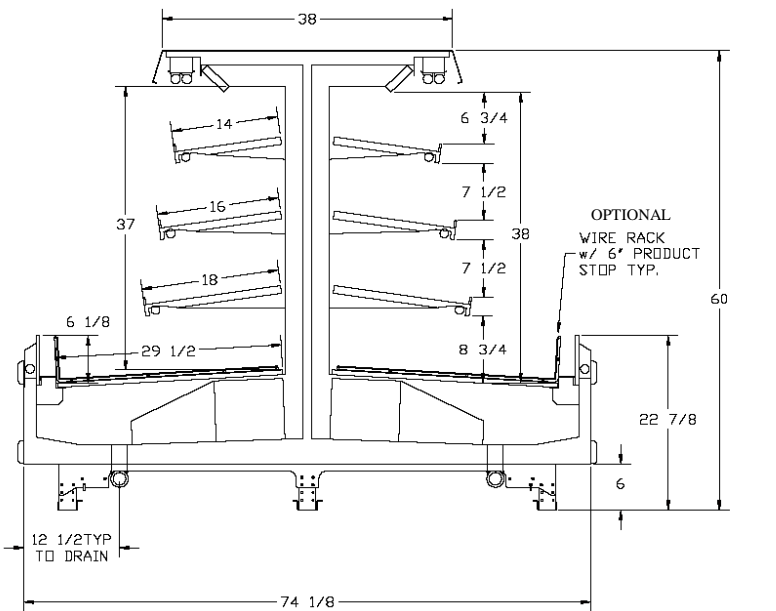

CENTER ISLAND CROSS-SECTION

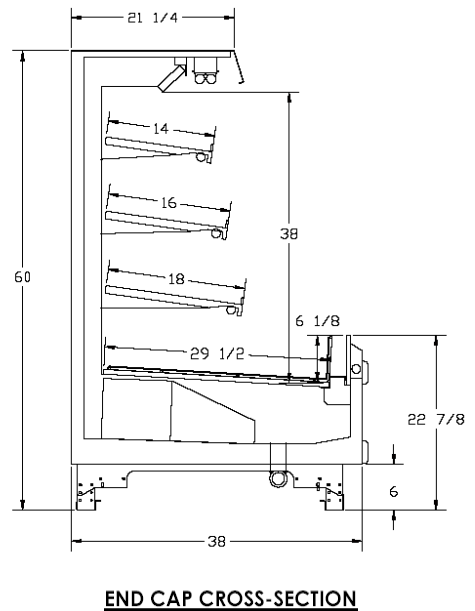

END CAP CROSS-SECTION

specialty
fabricators

118 meany road
wrightstown, nj 08562
www.specialtyfabricators.com
609-758-6995



3PSNCI Narrow Multi-deck "School Bus" Island

LIGHTING SPECS				
CASE	MAX#	ROWS	BULBS/ROW	120V
EC	5		2	2.5A 300W
4'CI	10		1	2.5A 300W
6'CI	10		2	5A 600W
8'CI	10		2	5A 600W
10'CI	10		3	7.5A 900W
12'CI	10		3	7.5A 900W

FANS SPECS		STANDARD	HI EFFICIENCY
CASE	FANS#	120V	120V
EC	2	.50A 60W	.26A 32W
4'CI	4	1A 120W	.52A 64W
6'CI	4	1A 120W	.52A 64W
8'CI	6	1.5A 180W	.78A 96W
10'CI	6	1.5A 180W	.78A 96W
12'CI	10	2.5A 300W	1.30A 160W

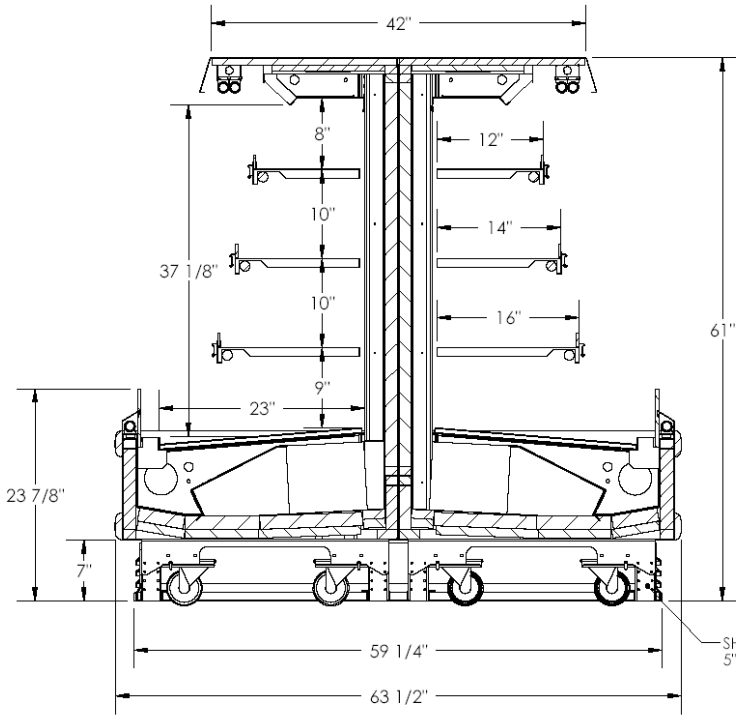

CENTER ISLAND CROSS-SECTION

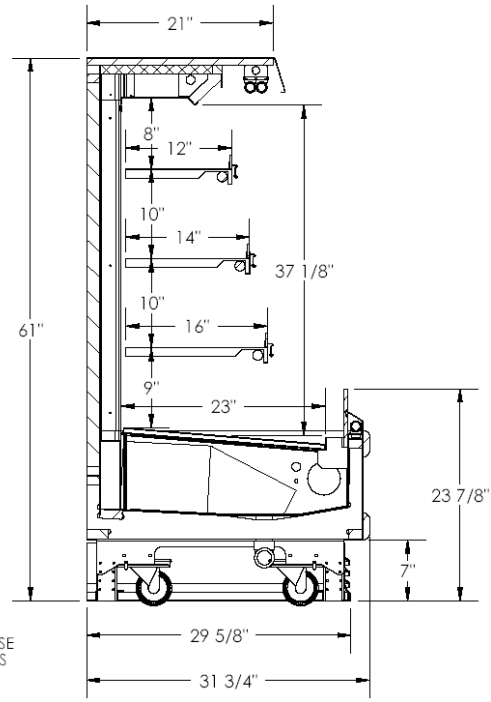

END CAP CROSS-SECTION

SHOWN ON 7" BASE
5", 6" & 7" OPTIONS

specialty
fabricators

118 meany road
wrightstown, nj 08562
www.specialtyfabricators.com
609-758-6995



28
These Merchandisers are designed for use in stores where temperatures and humidity do not exceed 75°F and 55% R.H. (We reserve the right to change or revise specifications and product design in connection with any feature of our products. Such changes do not entitle the buyer to corresponding changes, improvements, additions, or replacement of equipment Previously sold or shipped.)





specialty fabricators

MMR



MMR Self-Contained Spot Merchandiser

Applications:

- Deli
- Cheese
- Meat
- Salad
- Beverage
- Floral
- Impulse

Features

- Available in 2', 30", 3', 4', 5', and 6' lengths.
- Exterior and interior of case is available in stainless or custom color.
- Customized exterior to fit store décor.
- Self-contained unit uses environmentally friendly R134 refrigerant.
- Drain pan designed for quick removal and easy cleaning.
- 1" cart guard bumper.
- Full-view ends.
- Plexiglas front and end glass
- Solar digital thermometer.
- Electronic Ballasts
- Locking heavy duty semi-concealed castors.
- 115V / 20A dedicated 6' cord w/plug.
- Custom heights, lengths, depths and features.
- Also available as a Remote unit.

Options:

- Remote model
- Remote Glycol Refrigerant
- Case-top condenser hot air exhaust
- Adjustable (height/angle) dry wire shelf w/ T-8 lighting and price tag molding.
- Solid contour end panels
- Tempered front and end glass
- Rear sill Lighting
- Front sill lighting
- LED lighting
- Night curtain

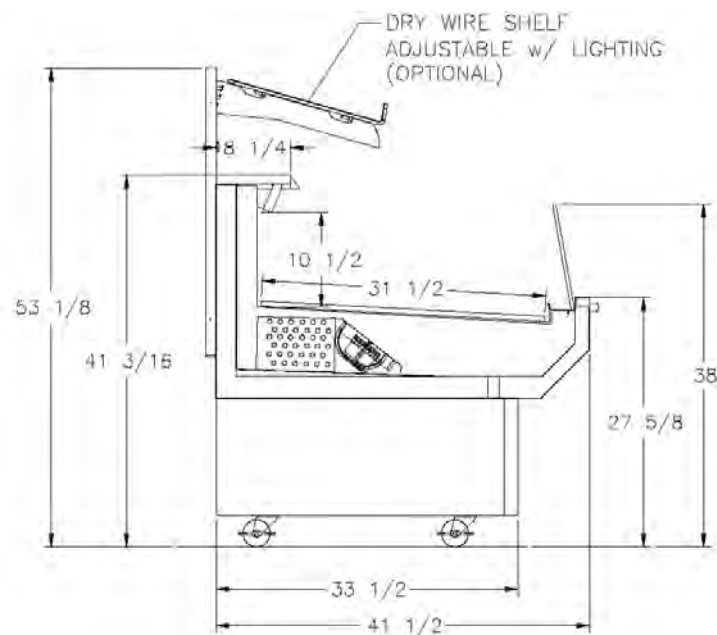

MMR-46 Self-Contained Merchandiser

Applications:

- Deli
- Cheese
- Meat
- Salad
- Beverage
- Impulse

Features

- Available in 2', 3', 4', 5', and 6' lengths.
- Exterior and interior of case is available in stainless or custom color.
- Customized exterior to fit store décor.
- Self-contained unit uses environmentally friendly R134 refrigerant.
- Drain pan designed for quick removal and easy cleaning.
- 1" cart guard bumper
- Full-view ends
- Plexiglas front and end glass
- Solar digital thermometer
- Locking heavy duty semi-concealed castors.
- 115V / 20A dedicated 6' cord w/plug.
- Custom lengths and features available.
- Also available as a Remote unit.

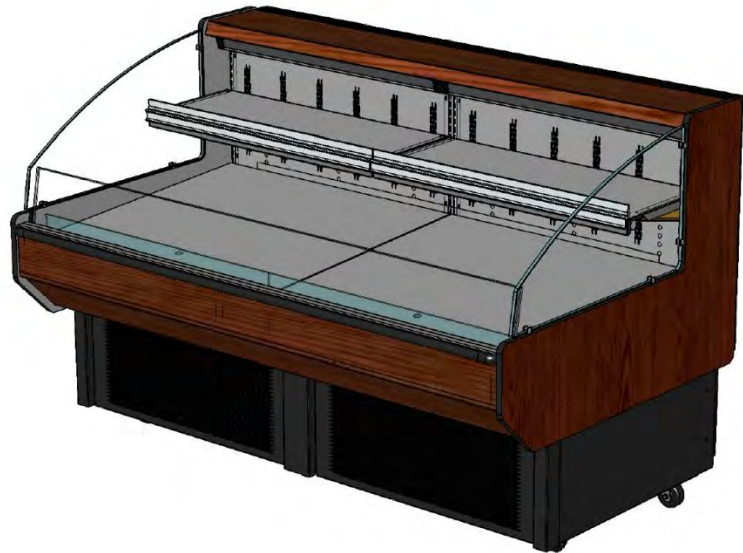

Options:

- Remote model
- Remote Glycol Refrigerant
- Case-top condenser hot air exhaust
- Adjustable (height) shelf w/ LED lighting and price tag molding. (1) Max.
- Adjustable (height/angle) dry wire shelf w/ LED lighting and price tag molding.
- Solid contour end panels
- Tempered front and end glass
- Rear sill lighting
- Front sill lighting
- Night curtain

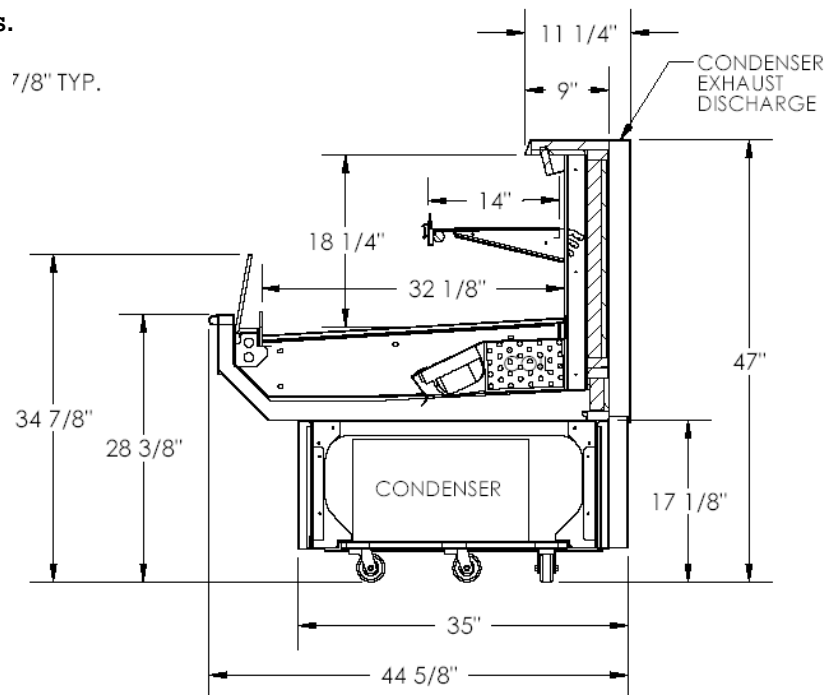

MMR-54 Self-Contained Merchandiser

Applications:

- Deli
- Cheese
- Meat
- Salad
- Beverage
- Impulse

Features

- Available in 2', 3', 4', 5', and 6' lengths.
- Exterior and interior of case is available in stainless or custom color.
- Customized exterior to fit store décor.
- Self-contained unit uses environmentally friendly R134 refrigerant.
- Drain pan designed for quick removal and easy cleaning.
- 1" cart guard bumper.
- Full-view ends.
- Plexiglas front and end glass
- Solar digital thermometer.
- Locking heavy duty semi-concealed castors.
- 115V / 20A dedicated 6' cord w/plug.
- Custom lengths, depths and features available.
- Also available as a Remote unit.

Options:

- Remote model
- Remote Glycol Refrigerant
- Case-top condenser hot air exhaust
- Adjustable (height) shelves w/ LED lighting and price tag molding. (2) Max.
- Adjustable (height/angle) dry wire shelf w/ LED lighting and price tag molding.
- Solid contour end panels
- Tempered front and end glass
- Rear sill lighting
- Front sill lighting
- Night curtain

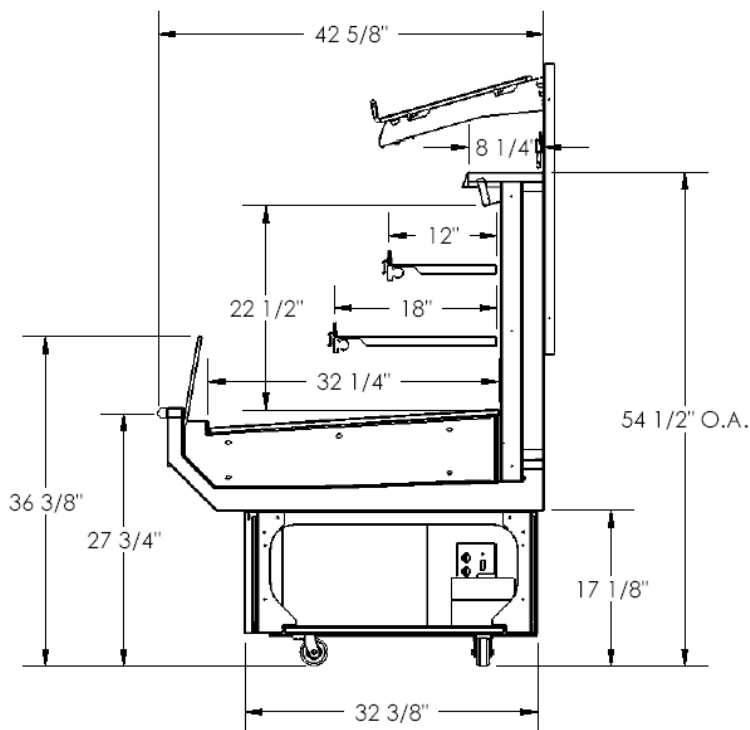

MMR-62 Self-Contained Merchandiser

Applications:

- Deli
- Cheese
- Meat
- Salad
- Beverage
- Impulse

Features

- Available in 2', 3', 4', 5', and 6' lengths.
- Exterior and interior of case is available in stainless or custom color.
- Customized exterior to fit store décor.
- Self-contained unit uses environmentally friendly R134 refrigerant.
- Drain pan designed for quick removal and easy cleaning.
- 1" or 2" cart guard bumper.
- Full-view ends.
- Plexiglas front and end glass
- Solar digital thermometer
- Locking heavy duty semi-concealed castors.
- 115V / 20-30A dedicated 6' cord w/plug.
- Custom lengths and features available.
- Also available as a Remote unit.

Options:

- Remote model
- Remote Glycol Refrigerant
- Case-top condenser hot air exhaust
- Adjustable (height) shelves w/ LED lighting and price tag molding. (2) Max.
- Adjustable (height/angle) dry wire shelf w/ LED lighting and price tag molding.
- Solid contour end panels
- Tempered front and end glass
- Front sill lighting
- Night curtain

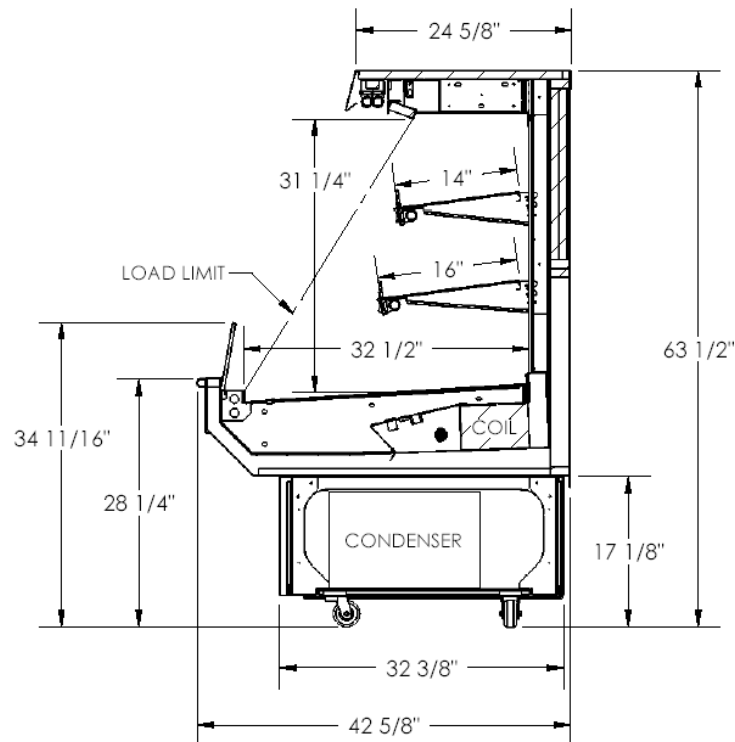

MMRNA Self-Contained Merchandiser

Applications:

- Deli
- Cheese
- Meat
- Salad
- Beverage
- Impulse

Features

- Available in 2', 3', 4', 5', and 6' lengths.
- Exterior and interior of case is available in stainless or custom color.
- Customized exterior to fit store décor.
- Self-contained unit uses environmentally friendly R134 refrigerant.
- Drain pan designed for quick removal and easy cleaning.
- 1" cart guard bumper.
- Full-view ends.
- Plexiglas front and end glass
- Solar digital thermometer.
- Locking heavy duty semi-concealed castors.
- 115V / 20A dedicated 6' cord w/plug.
- Custom lengths and features available upon request.
- Also available as a Remote unit.

Options:

- Remote model
- Night curtain
- Case-top condenser hot air exhaust
- Step shelf
- Adjustable (height/angle) dry wire shelf w/ LED lighting and price tag molding.
- Solid contour end panels
- Tempered front and end glass
- Front / Rear sill Lighting

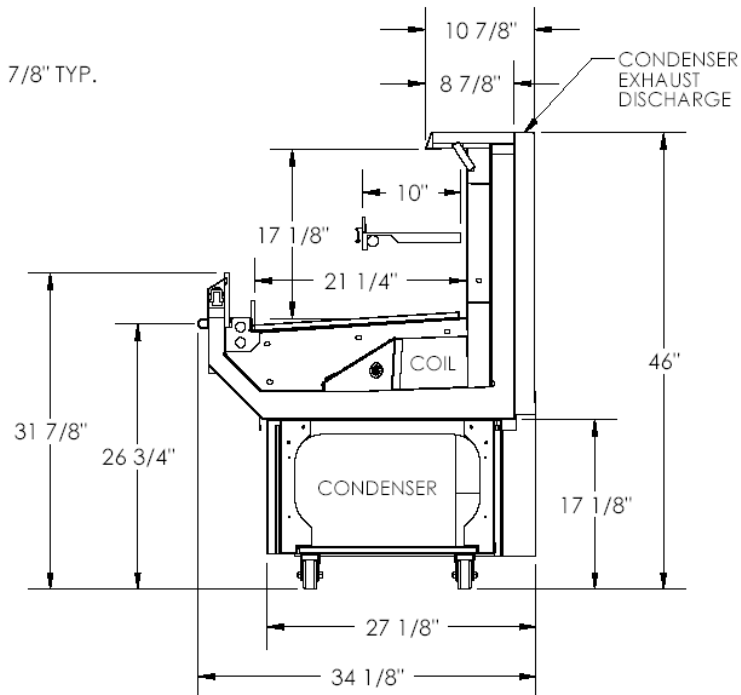

These Merchandisers are designed for use in stores where temperatures and humidity do not exceed 75°F and 55% R.H. (We reserve the right to change or revise specifications and product design in connection with any feature of our products. Such changes do not entitle the buyer to corresponding changes, improvements, additions, or replacement of equipment Previously sold or shipped.)

Top Air Exhaust

MMR-42

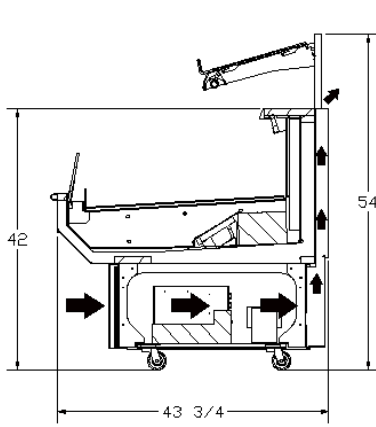

MMR-46

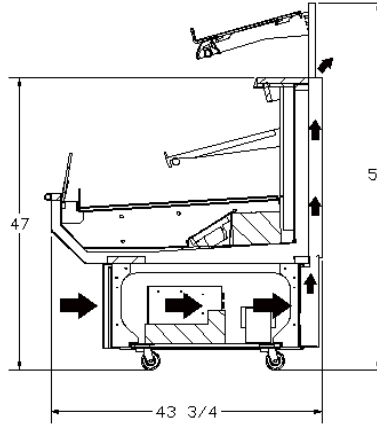

MMR-54

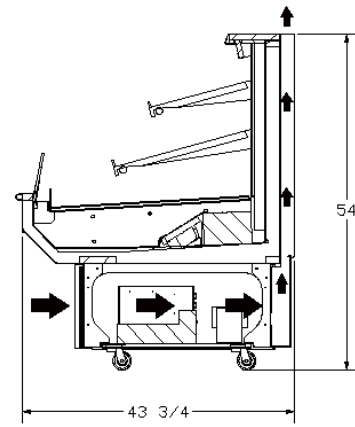

Applications:

- Deli
- Produce
- Bakery
- Front End

Features

Rear exhaust on these self-contained models has been beneficial in areas where hot exhaust air poses a problem, such as: Produce, Front, Ends and against walls or fixtures.

This system allows your merchandisers to bring refrigerated products into the center of your produce racks, introducing cross merchandising with related products, without jeopardizing the integrity of the surrounding produce.

Top exhaust of condenser air will make shopping conditions more comfortable for customers at the front end while checking out, giving you your last impulse opportunity.

Available on all MMR Case Models

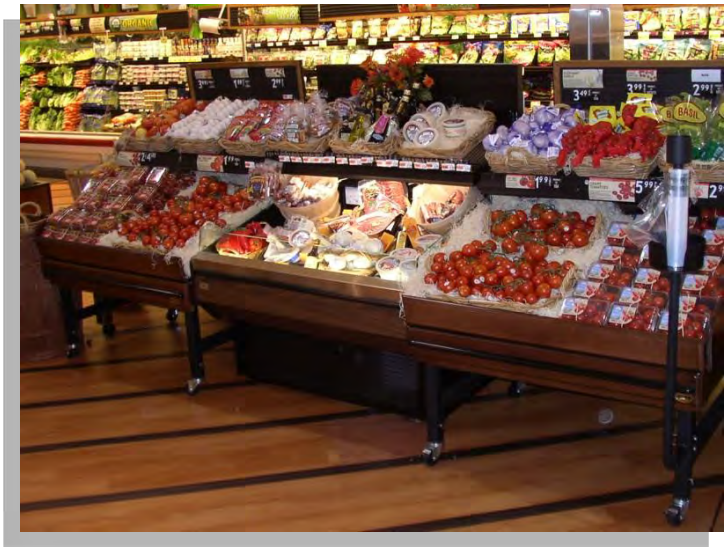

3PSNA-60 & 3PSNA-68

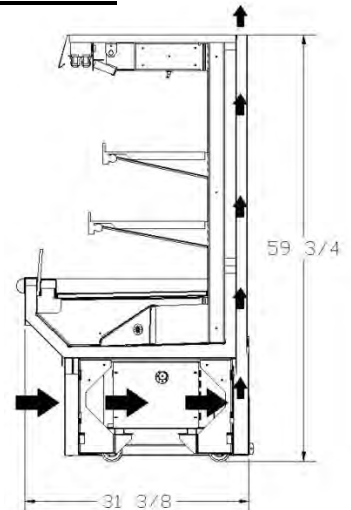

39

These Merchandisers are designed for use in stores where temperatures and humidity do not exceed 75°F and 55% R.H. (We reserve the right to change or revise specifications and product design in connection with any feature of our products. Such changes do not entitle the buyer to corresponding changes, improvements, additions, or replacement of equipment Previously sold or shipped.)



specialty
fabricators

118 meany road
wrightstown, nj 08562
www.specialtyfabricators.com
609-758-6995

MMR Olive Kiosk Single Deck Merchandiser

Applications:

- Olive
- Salad
- Deli

Features

- Available in 4' and 6' Lengths.
- Exterior and interior of case is available in stainless steel or custom color.
- Customized exterior to fit store décor.
- Tempered Glass Canopy
- 1" cart guard bumpers.
- Plexiglas front flue
- Solar digital thermometer.
- Custom lengths and features available upon request.
- Also available as a self-contained unit.

Options:

- Self-Contained
- Remote Glycol Refrigerant available
- LED lighting
- Night curtain
- Fully customizable case line

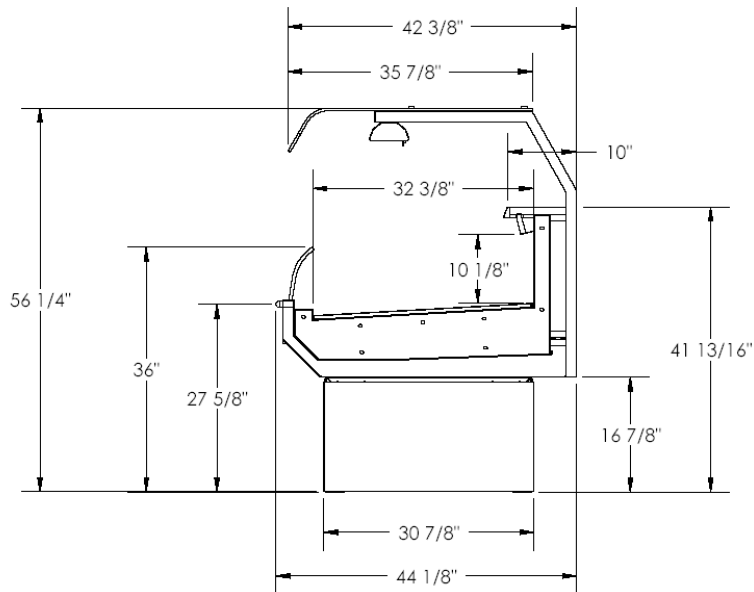
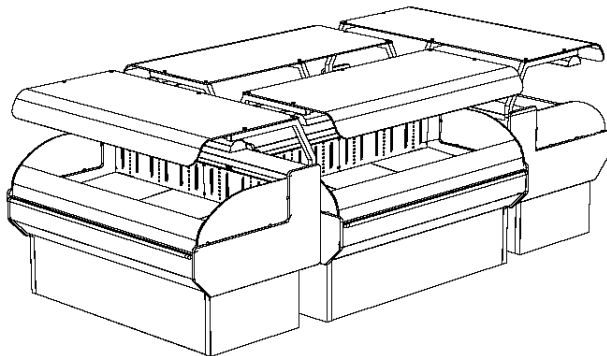

specialty
fabricators

118 meany road
wrightstown, nj 08562
www.specialtyfabricators.com
609-758-6995

MMR Single Deck Island Merchandiser

Applications:

- Deli
- Cheese
- Dairy
- Meat
- Salad
- Beverage
- Floral
- Impulse

Features

- Available in 3', 4', 5', and 6' lengths.
- Exterior and interior of case is available in stainless or custom color.
- Customized exterior to fit store décor.
- Self-contained unit uses environmentally friendly R134 refrigerant.
- Drain pan designed for quick removal and easy cleaning.
- Cart guard bumpers.
- 1" thermo pane front and end glass
- Plexiglas front flue
- Solar digital thermometer.
- Locking heavy duty semi-concealed castors.
- 115V / 20A dedicated 6' cord w/plug.
- Custom heights, lengths and features.
- Also available as a Remote unit.



Options:

- Self-Contained
- Remote Glycol Refrigerant available
- LED lighting
- Night curtain
- Fully customizable case line

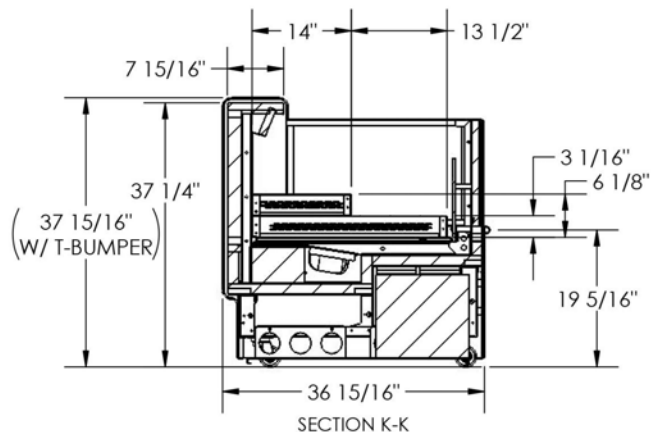

MMR-W Single Deck with optional Service Case

Applications:

- Olive
- Salad
- Deli
- Cheese

Features

- Available in 2' thru 10' Lengths.
- Exterior and interior of case is available in stainless steel or custom color.
- Customized exterior to fit store décor.
- Pedestal Base
- Tempered "lift-up" sneeze glass (Service case only)
- Thermopane front flue glass
- 2" cart guard bumper.
- 1" Plexiglas end glass (optional)
- Solar digital thermometer.
- Custom lengths, depths and features available upon request.
- Also available as a self-contained unit.

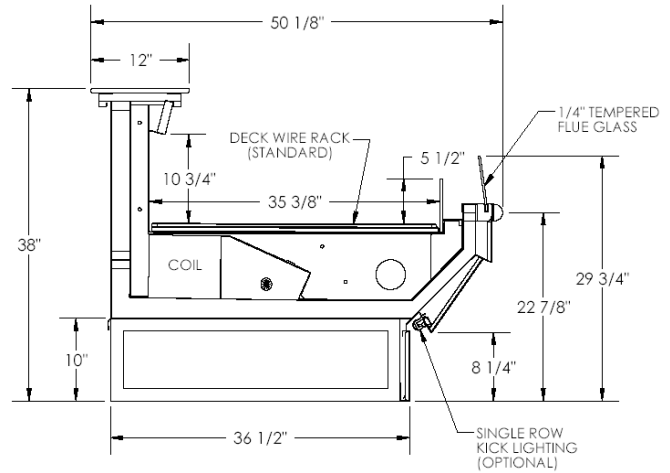

Options:

- Self-Contained up to 6' length
- LED lighting
- Kick lighting
- Night curtain
- Solid surface rear sill
- Expandable wire deck racks
- Remote Glycol Refrigerant available
- Fully customizable case line

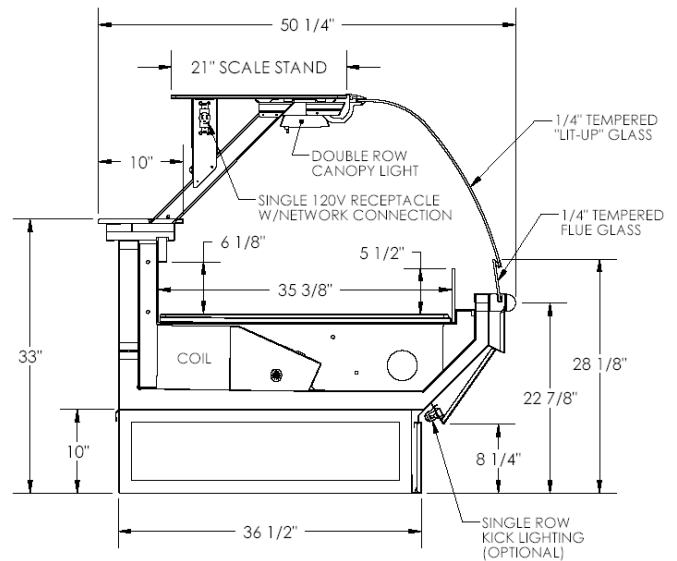

specialty
fabricators

118 meany road
wrightstown, nj 08562
www.specialtyfabricators.com
609-758-6995

MMR EURO Single Deck Merchandiser

Applications:

- Olive
- Salad
- Deli
- Cheese

Features

- Available in 4' thru 10' Lengths.
- Exterior and interior of case is available in stainless steel or custom color.
- Customized exterior to fit store décor.
- Pedestal Base
- Thermopane front flue glass
- 2" cart guard bumper
- 1" Plexiglas end glass (optional)
- Solar digital thermometer
- Custom lengths and features available upon request.
- Also available as a self-contained unit.



Options:

- Self-Contained *up to 6' in length
- LED lighting
- Night curtain
- Hard surface rear sill
- Expandable wire deck racks
- Remote Glycol Refrigerant available
- Fully customizable case line

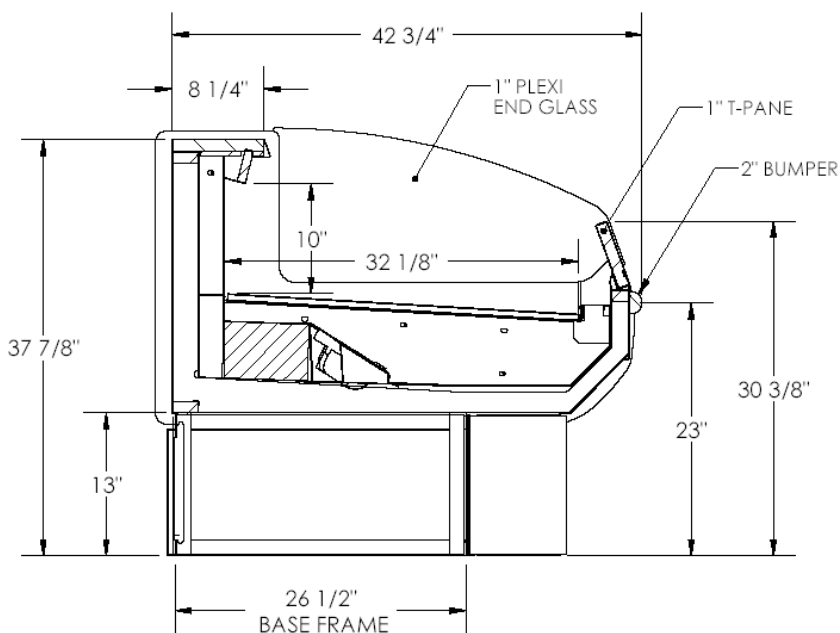

MMR EURO Single Deck Merchandiser with Service

Applications:

- Olive
- Salad
- Deli
- Cheese

Features

- Available in 4' thru 10' Lengths.
- Exterior and interior of case is available in stainless steel or custom color.
- Customized exterior to fit store décor.
- Pedestal Base
- Thermopane front flue glass
- 2" cart guard bumper
- 1" Plexiglas end glass (optional)
- Solar digital thermometer
- Custom lengths, depths and features available upon request.
- Also available as a self-contained unit.

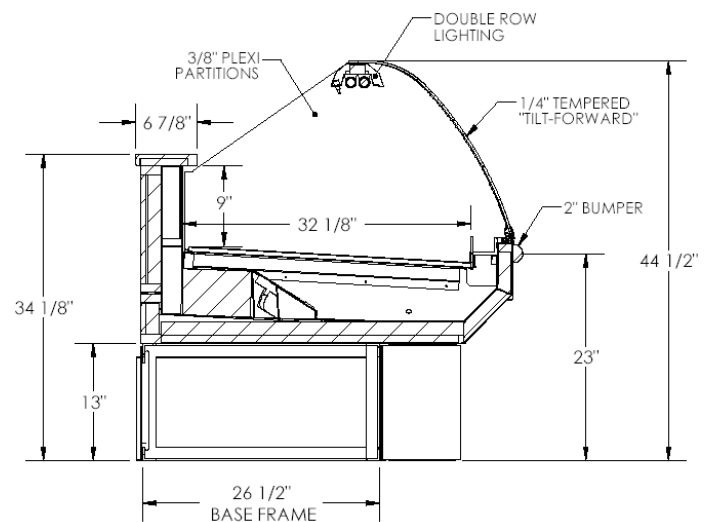
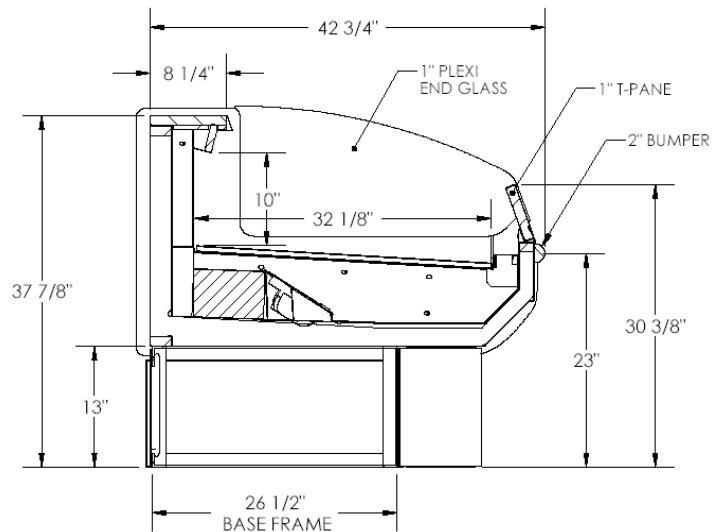

Options:

- Self-Contained *up to 6' length
- LED lighting
- Night curtain
- Hard surface rear sill
- Expandable wire deck racks
- Remote Glycol Refrigerant available
- Fully customizable case line



specialty
fabricators

118 meany road
wrightstown, nj 08562
www.specialtyfabricators.com
609-758-6995

MMR-42 / 46 Self-Contained Merchandiser

Applications:

- Deli
- Cheese
- Meat
- Salad
- Beverage
- Impulse



Features

- Available in 2', 3', 4', 5', and 6' lengths.
- Exterior and interior of case is available in stainless or custom color.
- Customized exterior to fit store décor.
- Self-contained unit uses environmentally friendly R134 refrigerant.
- Drain pan designed for quick removal and easy cleaning.
- 1" cart guard bumper
- Full-view ends
- Plexiglas front and end glass
- Solar digital thermometer
- Locking heavy duty semi-concealed castors.
- 115V / 20A dedicated 6' cord w/plug.
- Custom lengths, depths and features available.
- Also available as a Remote unit.

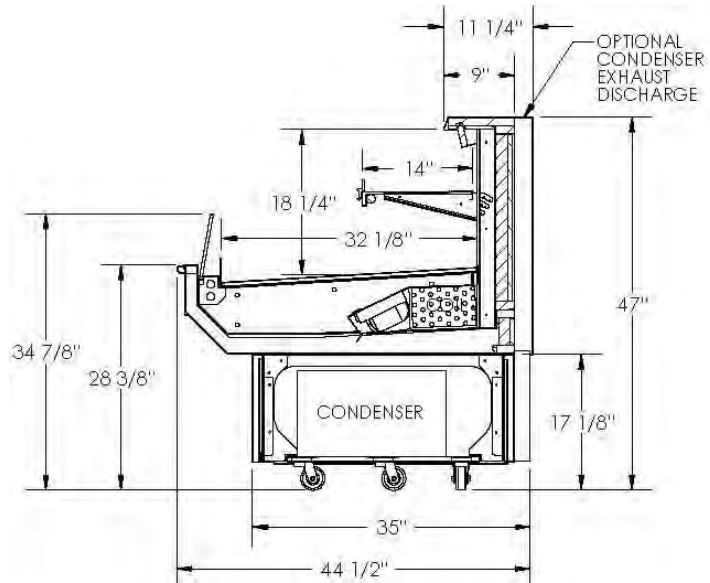

Options:

- Remote model
- Remote Glycol Refrigerant
- Case-top condenser hot air exhaust
- Adjustable (height) shelf w/ LED lighting and price tag molding. (1) Max.
- Adjustable (height/angle) dry wire shelf w/ LED lighting and price tag molding.
- Solid contour end panels
- Tempered front and end glass
- Rear sill lighting
- Front sill lighting
- Night curtain

