

Customized Soup Bar Merchandisers

Applications:

- Soup
- Hot Food

Features

- Customized exterior to fit store decor.
- Choose from 4qt., 7qt. or 11qt. soup wells
- Induction or Thermostat soup wells
- Stainless steel canopy structure
- Solid surface counter-tops
- 1" and 3" cart guard bumper
- Electronic Ballasts
- Custom lengths, depths and features

Options:

- Stainless steel counter-top.
- Custom color, solid surface or stainless steel canopy top.
- Lift-up tempered glass food guard
- Overhead heat lamps.
- Dry rear storage.
- Controls on front or rear of case.

Custom designed to meet your specific needs:

- Computer 3D Solid Modeled.
- Computer controlled parts production.
- The possibilities are endless!

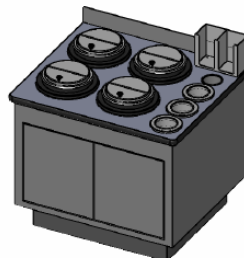
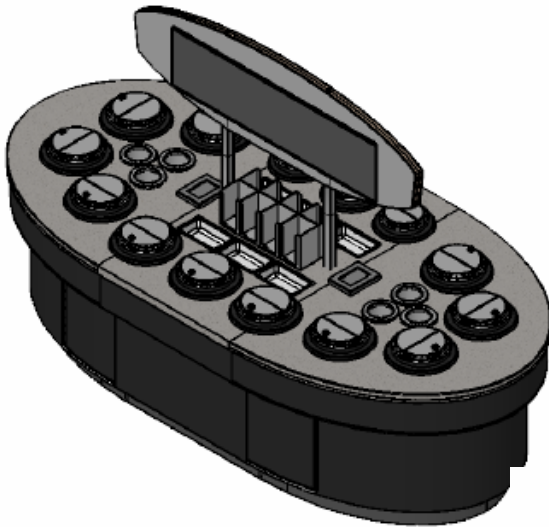

These Merchandisers are designed for use in stores where temperatures and humidity do not exceed 75°F and 55% R.H. (We reserve the right to change or revise specifications and product design in connection with any feature of our products. Such changes do not entitle the buyer to corresponding changes, improvements, additions, or replacement of equipment Previously sold or shipped.)

12

specialty
fabricators

118 meany road
wrightstown, nj 08562
www.specialtyfabricators.com
609-758-6995