



specialty
fabricators

SALAD, OLIVE,
SHRIMP & HOT FOOD
BARS



SSB "Flat Front" Single sided Salad Bar

Applications:

- Salad
- Olives

Features

- Available in 3 thru 14 pan lengths.
- Forced air-over pan refrigeration.
- 1 full pan width.
- Stainless steel tank liner.
- Customized exterior to fit store décor.
- Remote Unit
- Radial-top tempered glass food guard.
- Stainless steel food guard poles.
- Solid surface countertops.
- Custom color canopy top.
- 1" or 3" cart guard bumper.
- Solar digital thermometer.
- Custom lengths, depths and features available upon request.
- Also available as a Self-contained unit.



Options:

- Self-contained model.
- "Euro" pedestal kick panel. (shown)
- 3/8" tempered food guard shelf. (serv. side)
- Self-contained unit uses environmentally friendly R134 or R404 refrigerant.
- Drain pan designed for quick removal and easy cleaning.
- Stainless steel countertop.
- Remote Glycol Refrigerant.

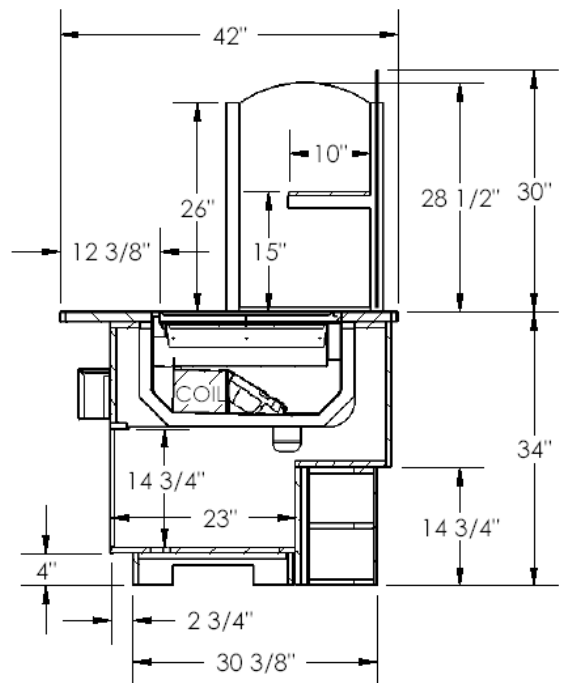

specialty
fabricators

118 meany road
wrightstown, nj 08562
www.specialtyfabricators.com
609-758-6995

These Merchandisers are designed for use in stores where temperatures and humidity do not exceed 75°F and 55% R.H. (We reserve the right to change or revise specifications and product design in connection with any feature of our products. Such changes do not entitle the buyer to corresponding changes, improvements, additions, or replacement of equipment Previously sold or shipped.)

SSB-3PS-EC Single sided Multi-Deck Salad Bar

Applications:

- Salad
- Olives

Features

- Available in 3 thru 14 pan lengths.
- Forced air-over pan refrigeration.
- Full pan depth - bottom shelf.
- Half pan depth - top shelf.
- Customized exterior to fit store décor.
- Remote Unit
- Lift-up tempered glass food guard.
- Stainless steel canopy pole structure.
- LED canopy lighting (2-rows).
- LED shelf lighting (1-row).
- Custom color canopy top.
- Container shelf.
- 1" and 3" cart guard bumper.
- Solar digital thermometer.
- Custom lengths, depths and features available upon request.
- Also available as a Self-contained unit.



Options:

- Self-contained unit uses environmentally friendly R134 or R404 refrigerant.
- Drain pan designed for quick removal and easy cleaning.
- Stainless steel or solid surface canopy top.
- Remote Glycol Refrigerant.

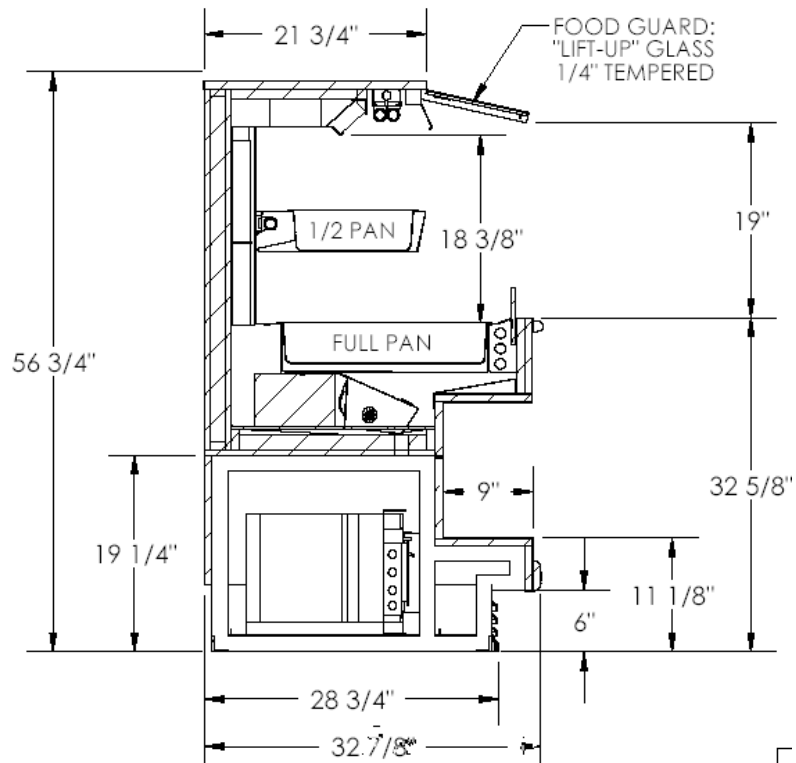

These Merchandisers are designed for use in stores where temperatures and humidity do not exceed 75°F and 55% R.H. (We reserve the right to change or revise specifications and product design in connection with any feature of our products. Such changes do not entitle the buyer to corresponding changes, improvements, additions, or replacement of equipment Previously sold or shipped.)

specialty
fabricators

118 meany road
wrightstown, nj 08562
www.specialtyfabricators.com
609-758-6995

SSB Single sided Salad Bar

Applications:

- Salad
- Olives

Features

- Available in 3 thru 14 pan lengths.
- Forced air-over pan refrigeration.
- 1 full pan width.
- Stainless steel tank liner.
- Customized exterior to fit store décor.
- Remote Unit
- Lift-up tempered glass food guard.
- Stainless steel canopy structure.
- LED canopy lighting (2-rows).
- Solid surface countertops.
- Custom color canopy top.
- Container shelf.
- 1" and 3" cart guard bumper.
- Solar digital thermometer.
- Custom lengths, depths and features available upon request.
- Also available as a Self-contained unit.



Options:

- Self-contained model.
- Self-contained unit uses environmentally friendly R134 or R404 refrigerant.
- Drain pan designed for quick removal and easy cleaning.
- Stainless steel countertop.
- Stainless steel or solid surface canopy top.
- Remote Glycol Refrigerant.

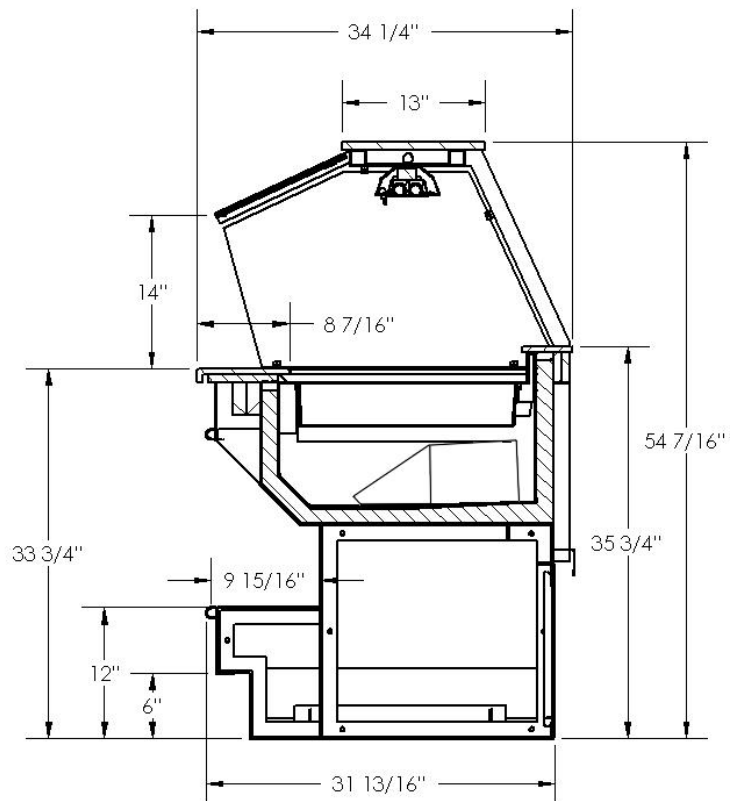

specialty
fabricators

118 meany road
wrightstown, nj 08562
www.specialtyfabricators.com
609-758-6995

SSB Single sided Salad Bar w/ curved front

Applications:

- Salad
- Olives

Features

- Available in 3 thru 14 pan lengths.
- Curved counter top and upper front panel.
- Forced air-over pan refrigeration.
- 1 full pan width.
- Stainless steel tank liner.
- Customized exterior to fit store décor.
- Remote Unit
- Lift-up tempered glass food guard.
- Stainless steel canopy structure.
- LED canopy lighting (2-rows).
- Solid surface countertops
- Custom color canopy top
- 1" cart guard bumper
- Solar digital thermometer
- Custom lengths, depths and features available upon request.
- Also available as a Self-contained unit.

Options:

- Self-contained model.
- LED lighting
- Self-contained unit uses environmentally friendly R134 or R404 refrigerant.
- Drain pan designed for quick removal and easy cleaning.
- Stainless steel countertop.
- Stainless steel or solid surface canopy top.
- Remote Glycol Refrigerant.

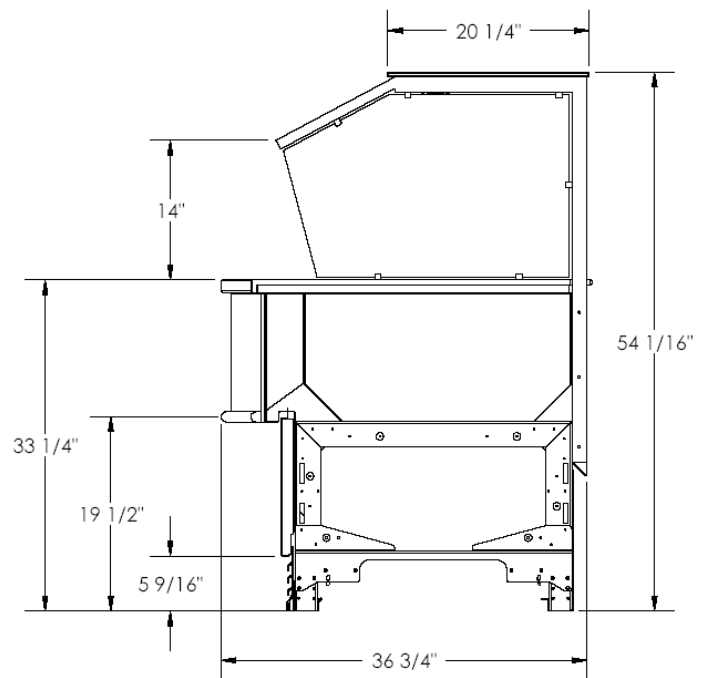

These Merchandisers are designed for use in stores where temperatures and humidity do not exceed 75°F and 55% R.H. (We reserve the right to change or revise specifications and product design in connection with any feature of our products. Such changes do not entitle the buyer to corresponding changes, improvements, additions, or replacement of equipment Previously sold or shipped.)

specialty
fabricators

118 meany road
wrightstown, nj 08562
www.specialtyfabricators.com
609-758-6995

SSB "DROP-IN" Single sided Salad Bar

Applications:

- Salad
- Olives
- Cheese

Features

- Available in 3 thru 14 pan lengths.
- Forced air-over pan refrigeration.
- 1 full pan width.
- Fully "convertible" interior.
- Stainless steel tank liner.
- Remote Unit
- Solar digital thermometer.
- Custom lengths, depths and features available upon request.
- Also available as a Self-contained unit.



Options:

- Self-contained model.
- Self-contained unit uses environmentally friendly R134 or R404 refrigerant.
- Drain pan designed for quick removal and easy cleaning.
- Remote Glycol Refrigerant.

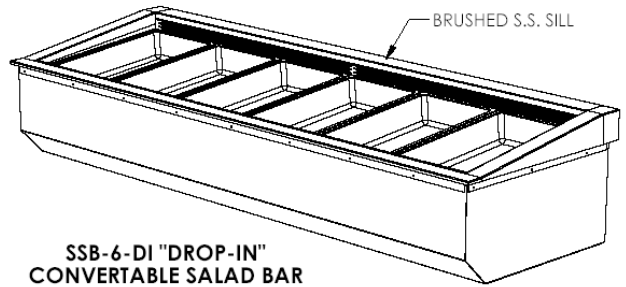

SSB-6-DI "DROP-IN"
CONVERTIBLE SALAD BAR
(SHOWN WITH SALAD PANS)

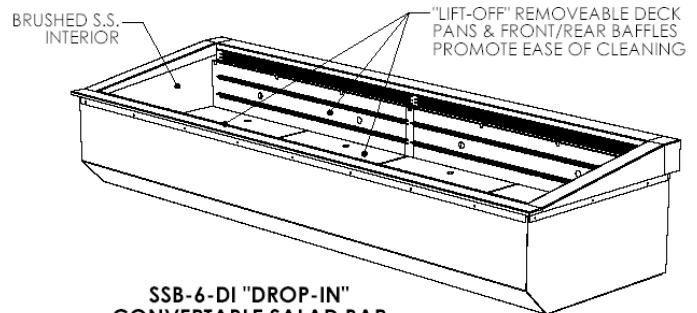

SSB-6-DI "DROP-IN"
CONVERTIBLE SALAD BAR
(SHOWN WITH SALAD PANS REMOVED)

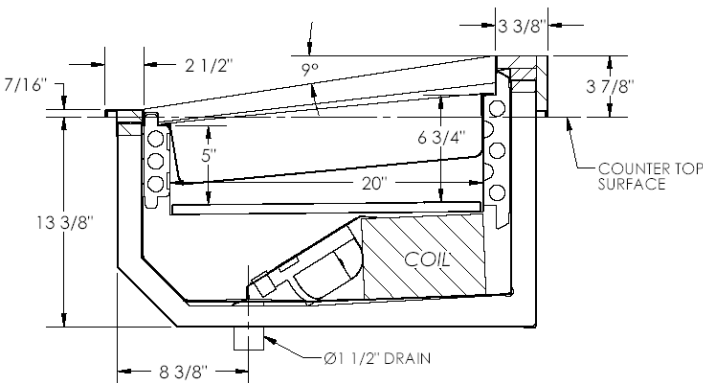

These Merchandisers are designed for use in stores where temperatures and humidity do not exceed 75°F and 55% R.H. (We reserve the right to change or revise specifications and product design in connection with any feature of our products. Such changes do not entitle the buyer to corresponding changes, improvements, additions, or replacement of equipment Previously sold or shipped.)

specialty
fabricators

118 meany road
wrightstown, nj 08562
www.specialtyfabricators.com
609-758-6995

WSB Self-Contained Mobile Shrimp Bar

Applications:

- Salad
- Olives
- Shrimp
- Wings

Features

- Available in 3, 4, 5, 6 pan lengths.
- Forced air-over pan refrigeration.
- 1 full pan width.
- Stainless steel tank liner.
- Customized exterior to fit store décor.
- Self-contained unit uses environmentally friendly R134 or R404 refrigerant.
- Lift-up tempered glass food guard.
- Stainless steel canopy structure.
- LED canopy lighting (2-rows).
- Stainless steel countertops.
- Stainless steel canopy top.
- Container shelves on both sides.
- Drain pan designed for quick removal and easy cleaning.
- Clean out valve for easy evacuation of wash water. (S/C models only.)
- 3" cart guard bumper.
- Solar digital thermometer.
- Locking heavy duty castors.
- 115V / 20A dedicated 6' cord w/plug.
- Custom lengths, depths and features available upon request.
- Also available as a Remote unit.

Options:

- Remote model
- Remote Glycol refrigerant
- Solid surface countertop
- Solid surface canopy top
- 4" stainless steel legs
- 1 1/2 pan width.
- Contour end panels

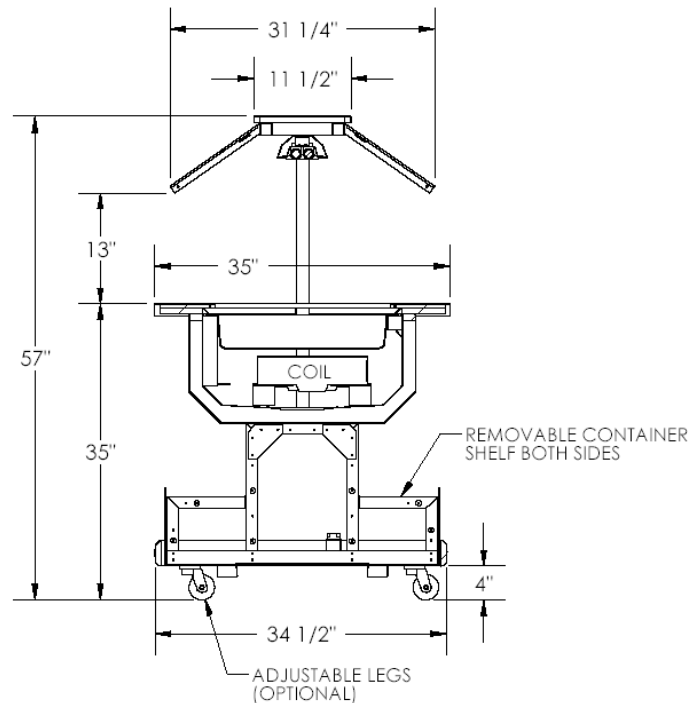

WSB-1



specialty
fabricators

118 meany road
wrightstown, nj 08562
www.specialtyfabricators.com
609-758-6995

WSB-1 Walk-Around Salad Bar

Applications:

- Salad
- Olives

Features

- Available in 3 thru 14 pan lengths.
- Forced air-over pan refrigeration.
- 1 & 1 1/2 full pan width.
- Stainless steel tank liner.
- Customized exterior to fit store décor.
- Remote Unit
- Lift-up tempered glass food guard.
- Stainless steel canopy structure.
- LED canopy lighting (2-rows).
- Solid surface countertops.
- Custom color canopy top.
- Container shelf both sides.
- 1" and 3" cart guard bumper.
- Solar digital thermometer.
- Custom lengths, depths and features available upon request.

Options:

- Self-contained model.
- Remote Glycol refrigerant
- Angled or flat pans
- Self-contained unit uses environmentally friendly R134 or R404 refrigerant.
- Drain pan designed for quick removal and easy cleaning.
- Clean out valve for easy evacuation of wash water. (S/C models only.)
- Stainless steel countertop.
- Stainless steel or solid surface canopy top.
- Flat front
- Utility end
- Soup end
- Refrigerated end pans



specialty
fabricators

118 meany road
wrightstown, nj 08562
www.specialtyfabricators.com
609-758-6995

WSB-1 Walk-Around Salad Bar

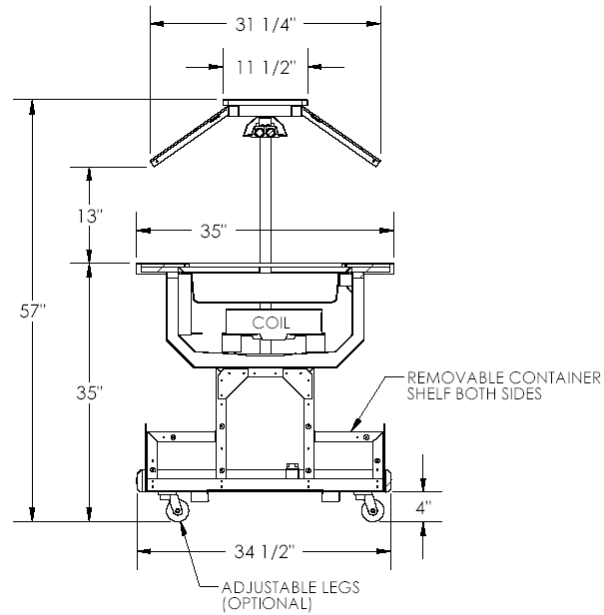

WSB-1

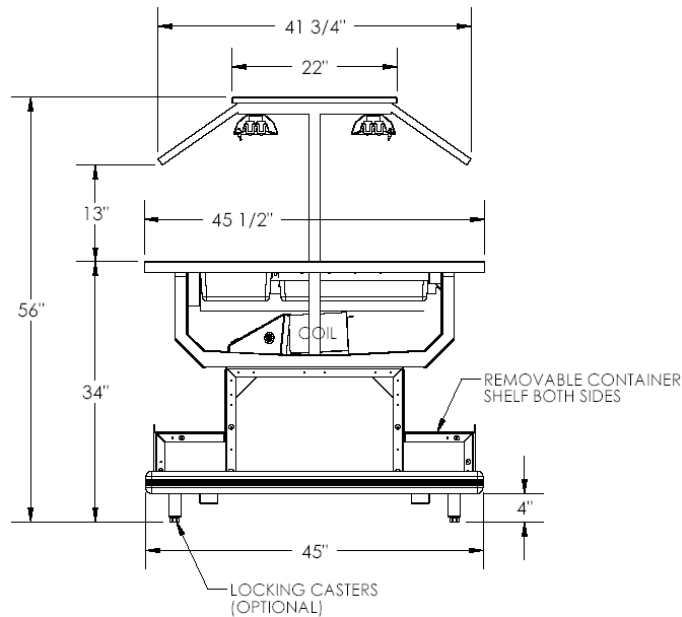

WSB-1 1/2



specialty
fabricators

118 meany road
wrightstown, nj 08562
www.specialtyfabricators.com
609-758-6995

These Merchandisers are designed for use in stores where temperatures and humidity do not exceed 75°F and 55% R.H. (We reserve the right to change or revise specifications and product design in connection with any feature of our products. Such changes do not entitle the buyer to corresponding changes, improvements, additions, or replacement of equipment Previously sold or shipped.)

WSB-1 Walk-Around "S" Salad Bar

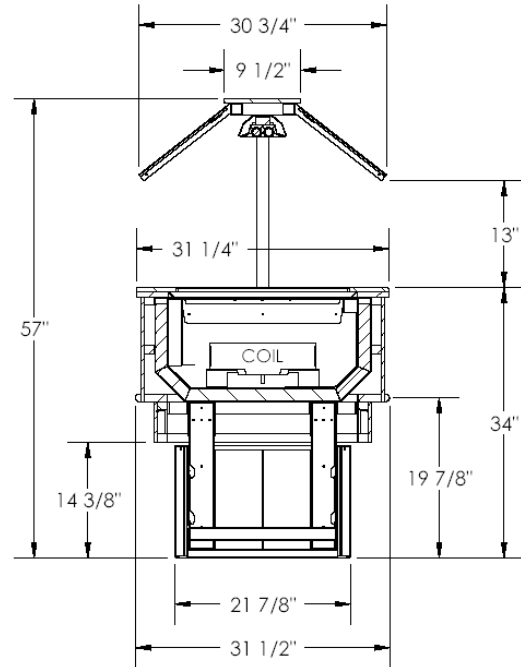
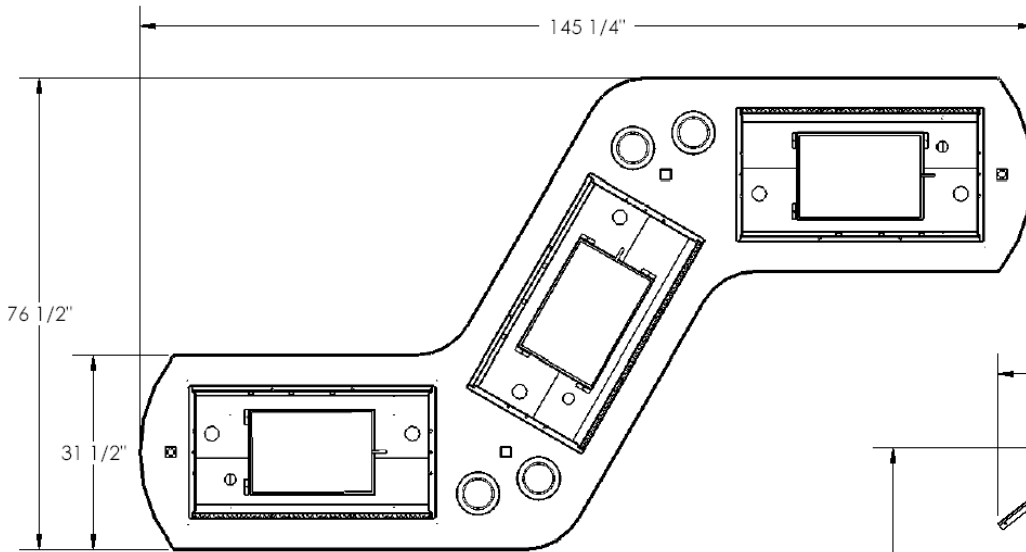

WSB-1 "S-BAR"



These Merchandisers are designed for use in stores where temperatures and humidity do not exceed 75°F and 55% R.H. (We reserve the right to change or revise specifications and product design in connection with any feature of our products. Such changes do not entitle the buyer to corresponding changes, improvements, additions, or replacement of equipment Previously sold or shipped.)

specialty
fabricators

118 meany road
wrightstown, nj 08562
www.specialtyfabricators.com
609-758-6995

WSB-2 Walk-Around Salad Bar

Applications:

- Salad
- Olives

Features

- Available in 3 thru 14 pan lengths.
- Forced air-over pan refrigeration.
- 2 full pan width.
- Stainless steel tank liner.
- Customized exterior to fit store décor.
- Remote Unit
- Lift-up tempered glass food guard.
- Stainless steel canopy structure.
- LED canopy lighting (4-rows).
- Solid surface countertops.
- Custom color canopy top.
- Container shelf both sides.
- 1" and 3" cart guard bumper.
- Solar digital thermometer.
- Custom lengths, depths and features available upon request.
- Also available as a Self-contained unit.

Options:

- Self-contained model.
- Remote Glycol refrigerant
- Angled or flat pans
- Self-contained unit uses environmentally friendly R134 or R404 refrigerant.
- Drain pan designed for quick removal and easy cleaning.
- Stainless steel countertop.
- Stainless steel or solid surface canopy top.
- Flat front
- Utility end
- Soup end
- Hot wells
- Heated shelves
- Refrigerated end pans



specialty
fabricators

118 meany road
wrightstown, nj 08562
www.specialtyfabricators.com
609-758-6995

These Merchandisers are designed for use in stores where temperatures and humidity do not exceed 75°F and 55% R.H. (We reserve the right to change or revise specifications and product design in connection with any feature of our products. Such changes do not entitle the buyer to corresponding changes, improvements, additions, or replacement of equipment Previously sold or shipped.)

WSB-2 Walk-Around Salad Bar with Container Shelf

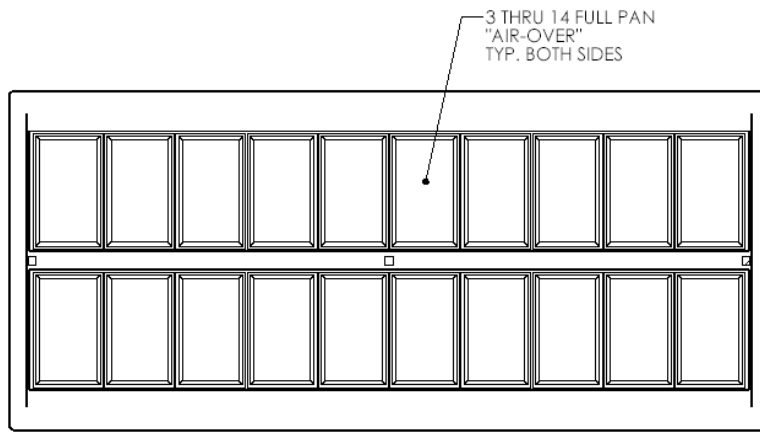
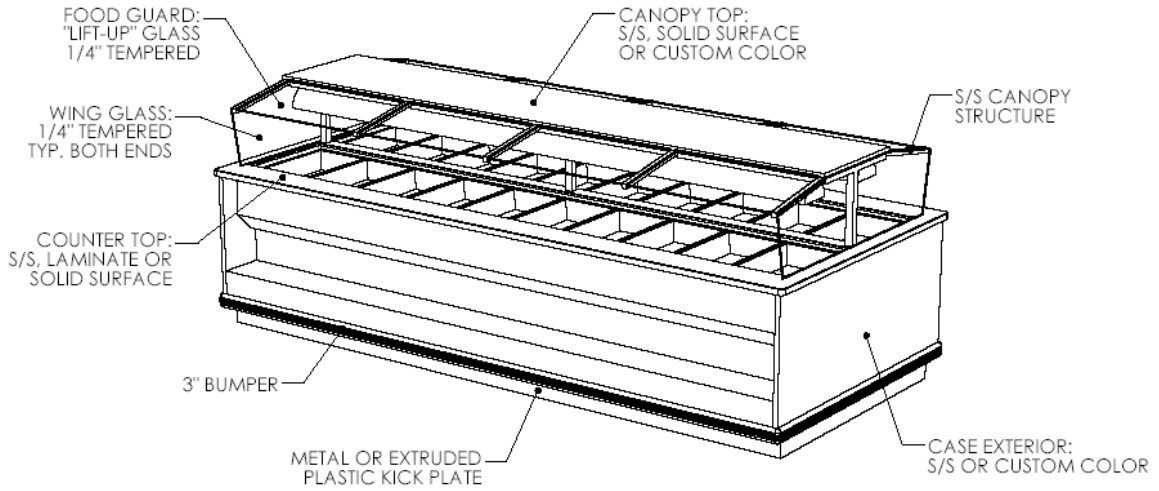

TOP VIEW

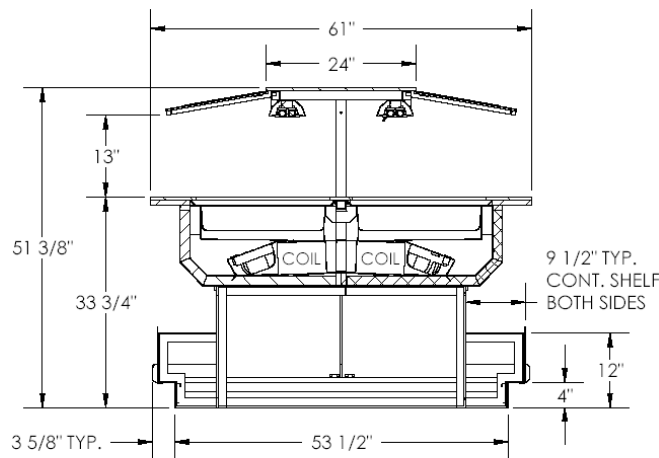

WSB-2

(FLAT PANS SHOWN)



specialty
fabricators

118 meany road
wrightstown, nj 08562
www.specialtyfabricators.com
609-758-6995

These Merchandisers are designed for use in stores where temperatures and humidity do not exceed 75°F and 55% R.H. (We reserve the right to change or revise specifications and product design in connection with any feature of our products. Such changes do not entitle the buyer to corresponding changes, improvements, additions, or replacement of equipment Previously sold or shipped.)

WSB-2 Walk-Around Salad Bar with End Pans

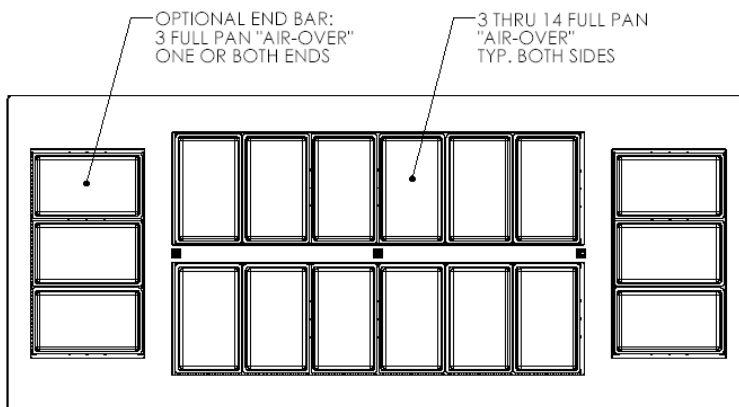
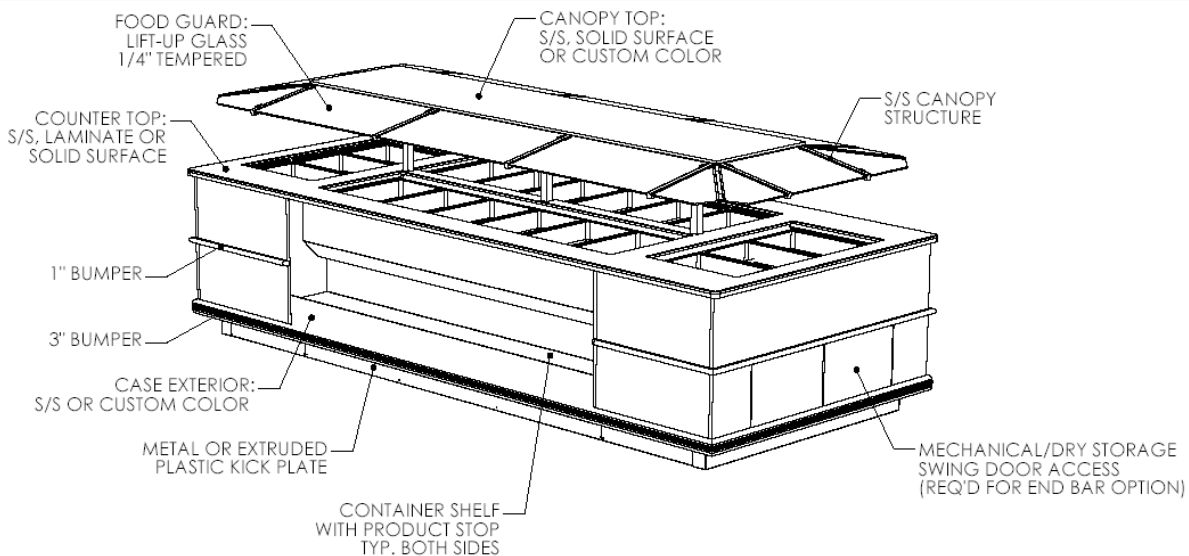

TOP VIEW

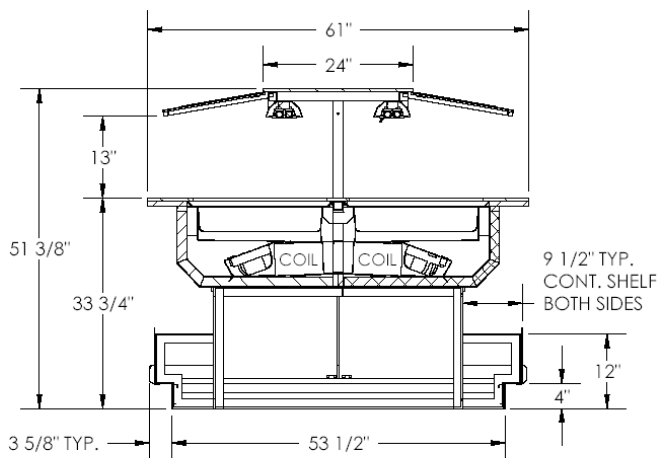

WSB-2

(FLAT PANS SHOWN)



specialty
fabricators

118 meany road
wrightstown, nj 08562
www.specialtyfabricators.com
609-758-6995

These Merchandisers are designed for use in stores where temperatures and humidity do not exceed 75°F and 55% R.H. (We reserve the right to change or revise specifications and product design in connection with any feature of our products. Such changes do not entitle the buyer to corresponding changes, improvements, additions, or replacement of equipment Previously sold or shipped.)

WSB-2 Walk-Around Salad Bar w/o Container Shelf

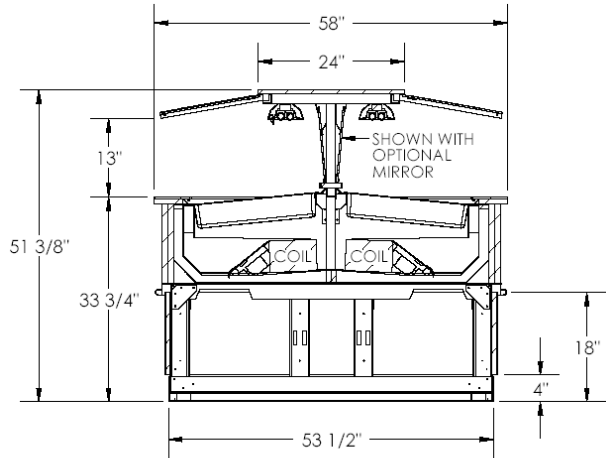
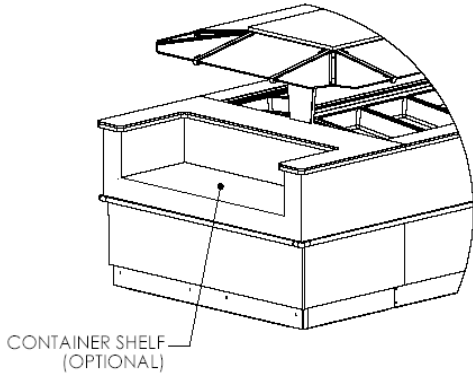
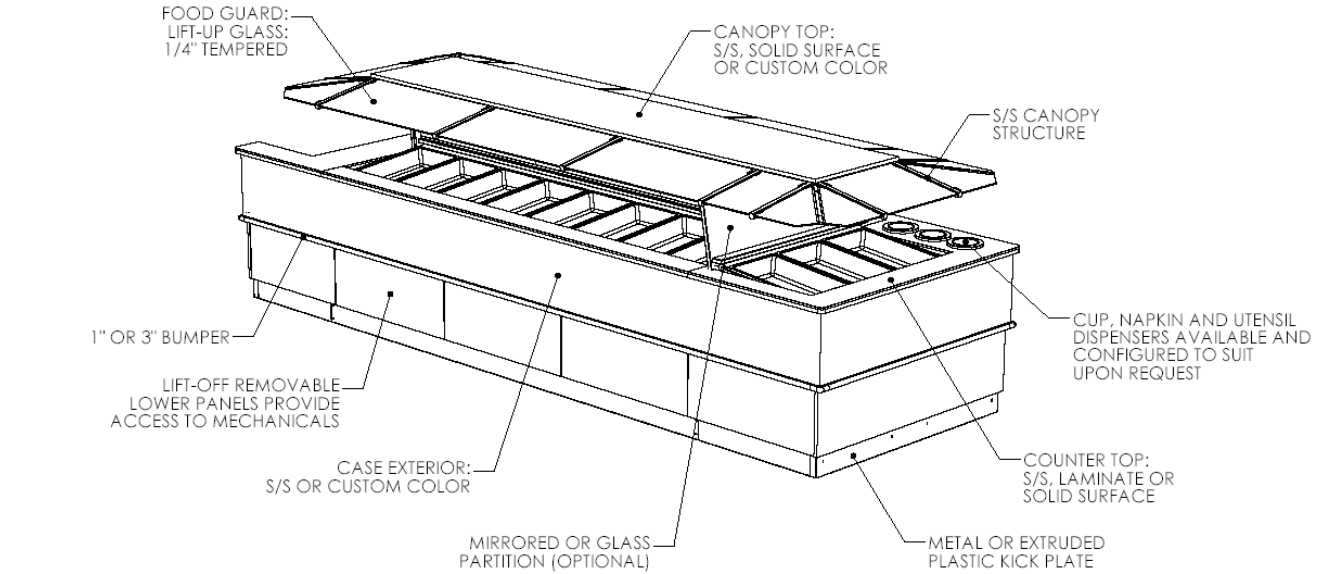

WSB-2
(ANGLED PANS SHOWN)

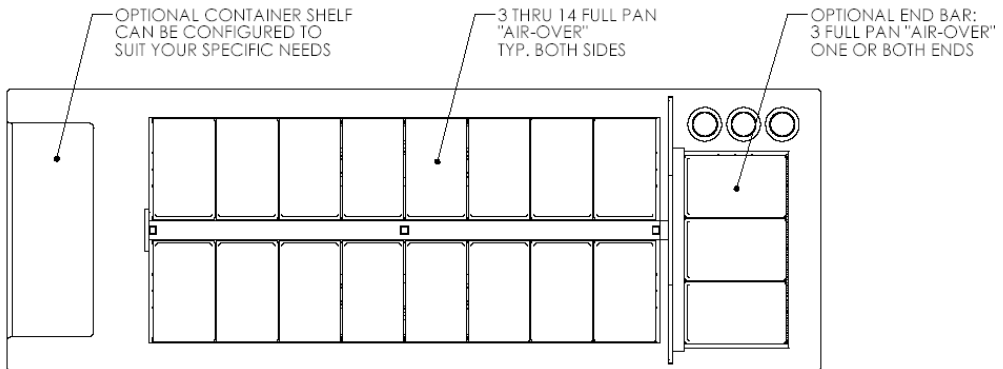

TOP VIEW



specialty
fabricators

118 meany road
wrightstown, nj 08562
www.specialtyfabricators.com
609-758-6995

These Merchandisers are designed for use in stores where temperatures and humidity do not exceed 75°F and 55% R.H. (We reserve the right to change or revise specifications and product design in connection with any feature of our products. Such changes do not entitle the buyer to corresponding changes, improvements, additions, or replacement of equipment Previously sold or shipped.)

WSB-2 Walk-Around Salad Bar with Kick Lighting

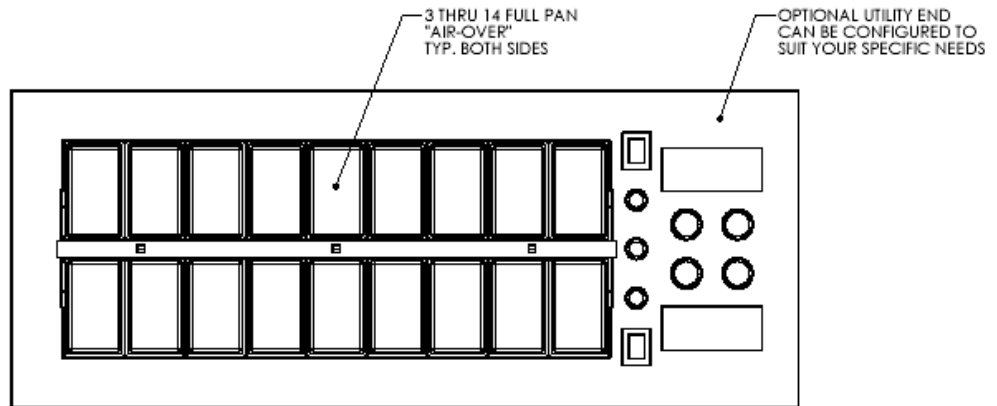
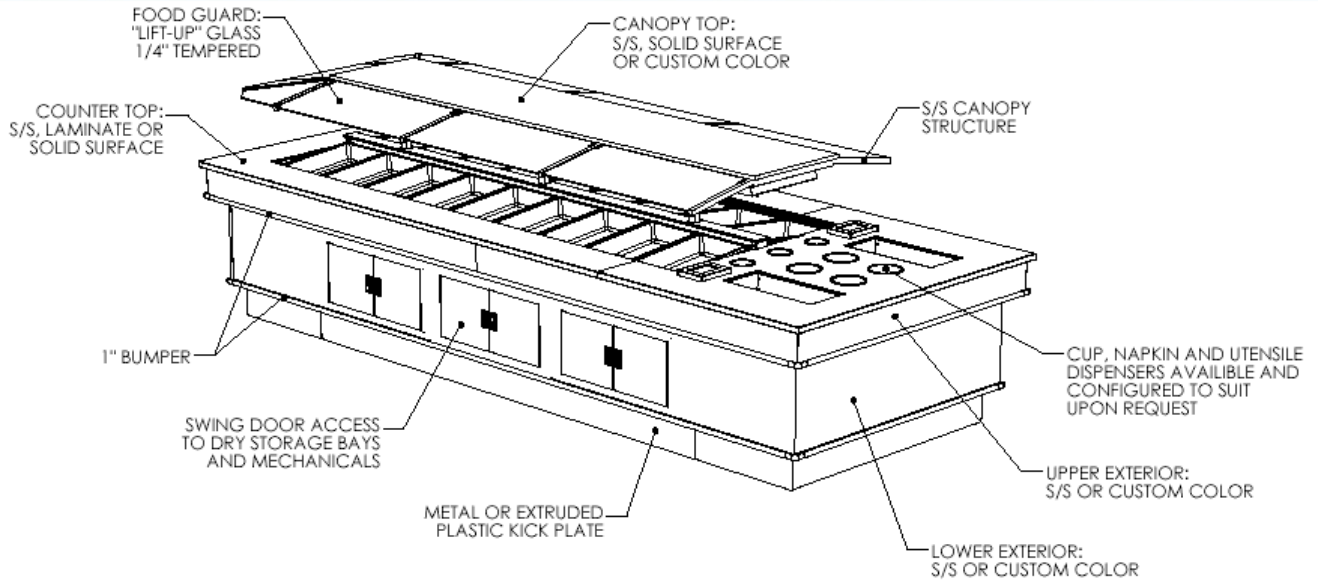

TOP VIEW

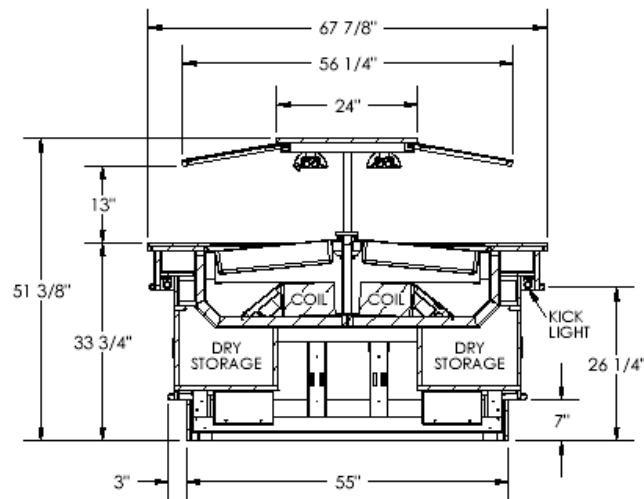

WSB-2

(ANGLED PANS SHOWN)



specialty
fabricators

118 meany road
wrightstown, nj 08562
www.specialtyfabricators.com
609-758-6995

These Merchandisers are designed for use in stores where temperatures and humidity do not exceed 75°F and 55% R.H. (We reserve the right to change or revise specifications and product design in connection with any feature of our products. Such changes do not entitle the buyer to corresponding changes, improvements, additions, or replacement of equipment Previously sold or shipped.)

WSB-2 Walk-Around Salad Bar with Soup End

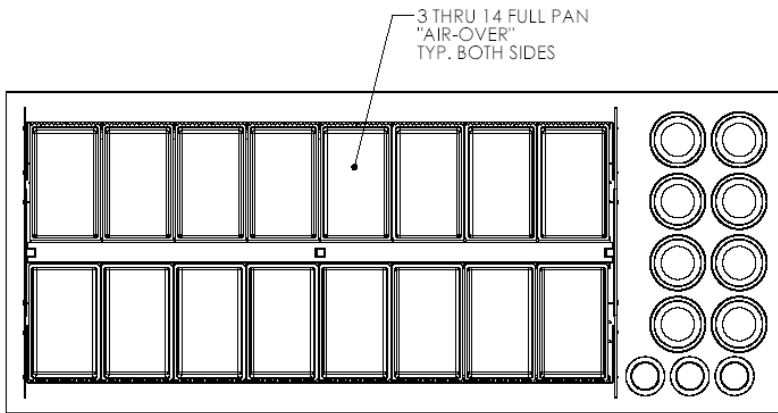
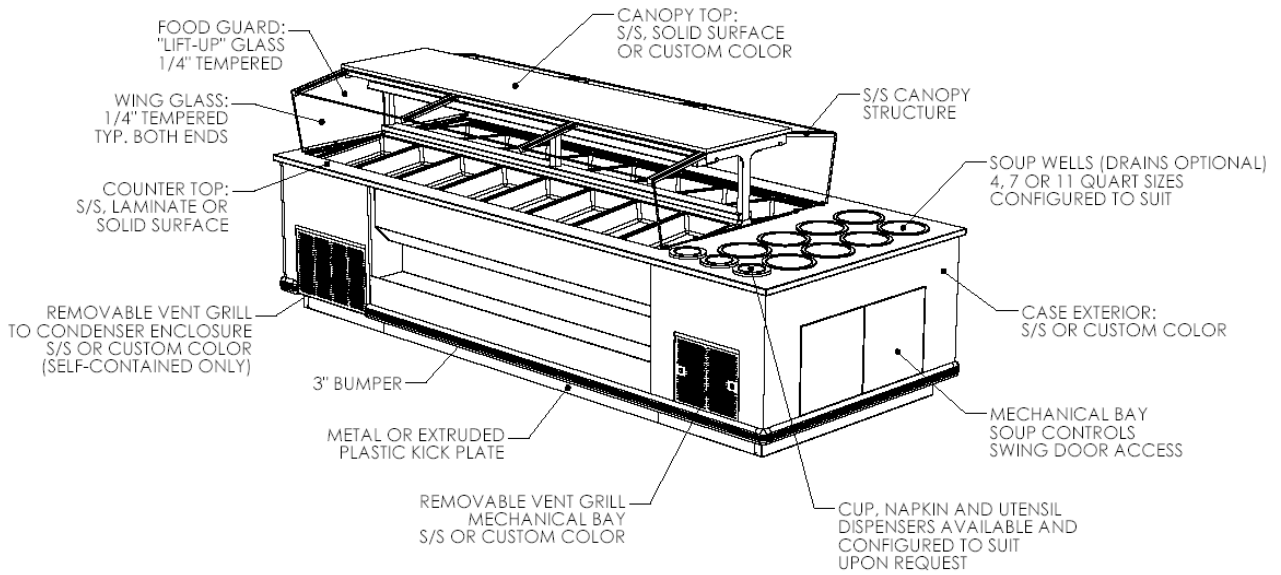

TOP VIEW

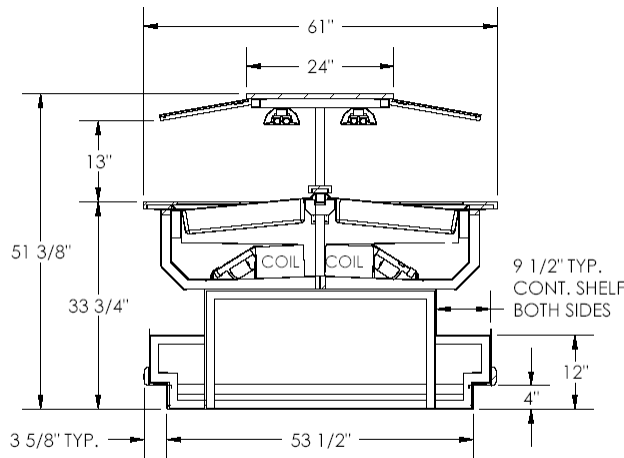

WSB-2-S

(ANGLED PANS SHOWN)



specialty
fabricators

118 meany road
wrightstown, nj 08562
www.specialtyfabricators.com
609-758-6995

These Merchandisers are designed for use in stores where temperatures and humidity do not exceed 75°F and 55% R.H. (We reserve the right to change or revise specifications and product design in connection with any feature of our products. Such changes do not entitle the buyer to corresponding changes, improvements, additions, or replacement of equipment Previously sold or shipped.)

WSB-2 Walk-Around Salad Bar with Radial Soup End

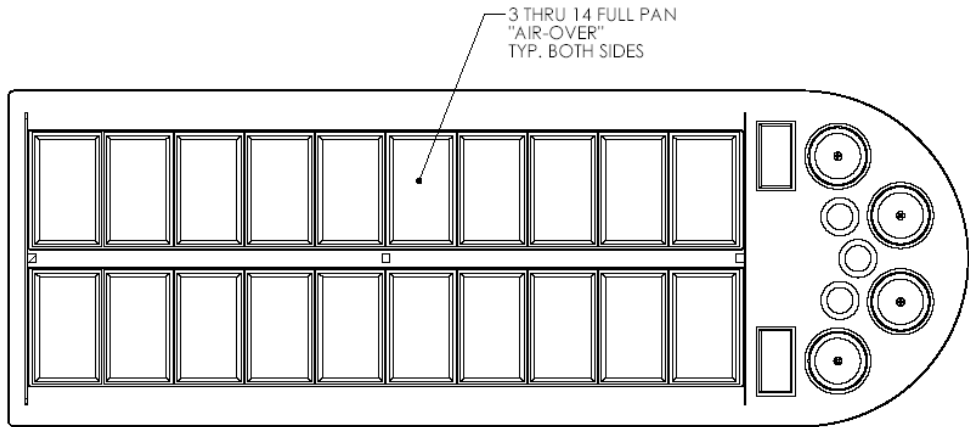
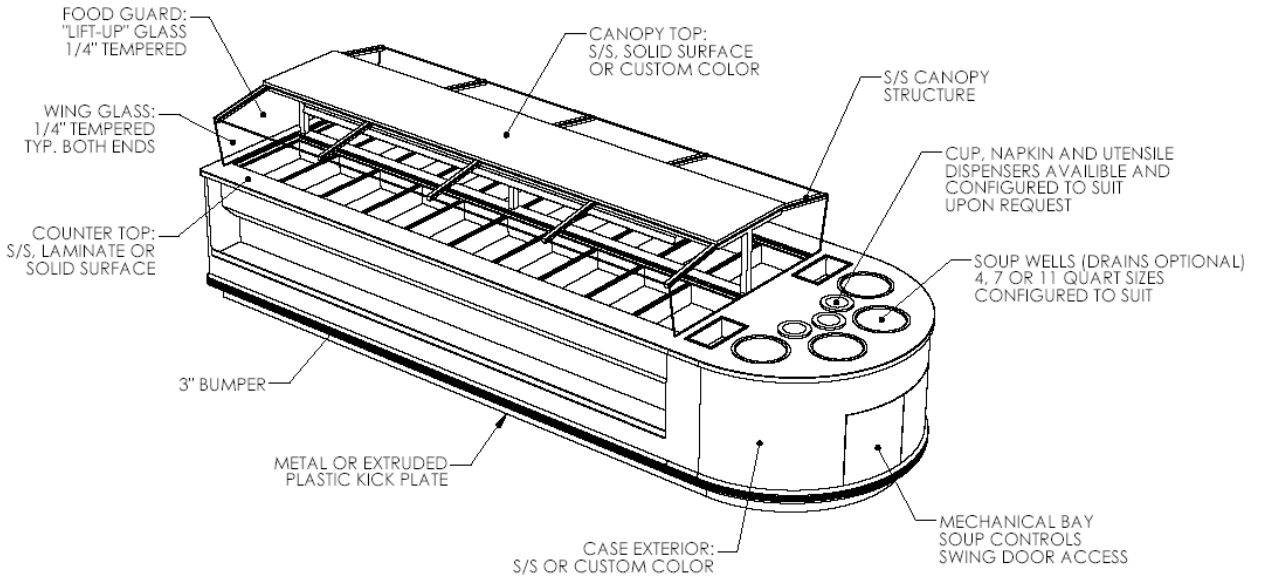

TOP VIEW

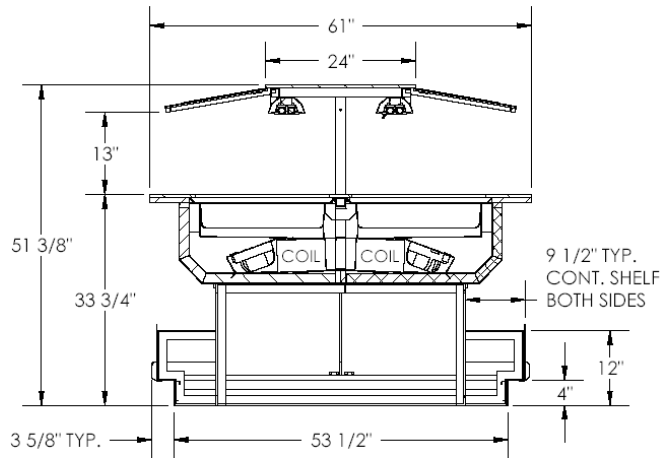

WSB-2

(FLAT PANS SHOWN)



specialty
fabricators

118 meany road
wrightstown, nj 08562
www.specialtyfabricators.com
609-758-6995

These Merchandisers are designed for use in stores where temperatures and humidity do not exceed 75°F and 55% R.H. (We reserve the right to change or revise specifications and product design in connection with any feature of our products. Such changes do not entitle the buyer to corresponding changes, improvements, additions, or replacement of equipment Previously sold or shipped.)

WSB-2 Walk-Around Salad Bar Hot/Cold with Soup End

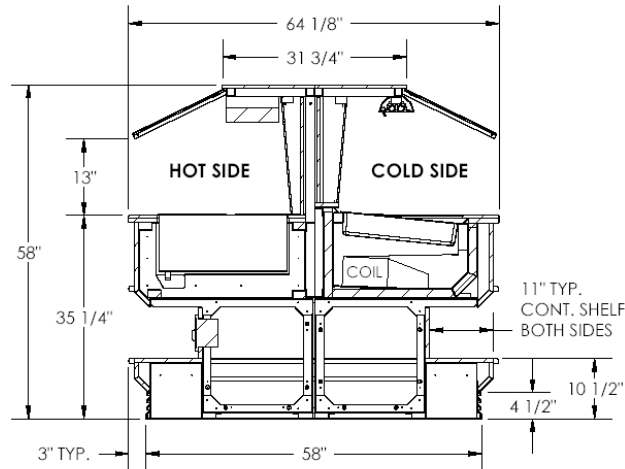
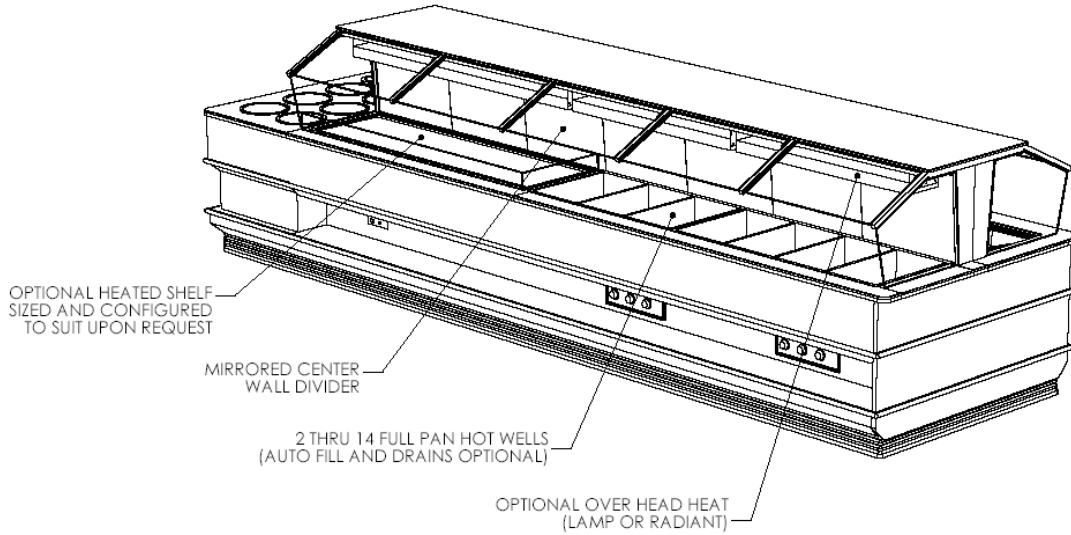
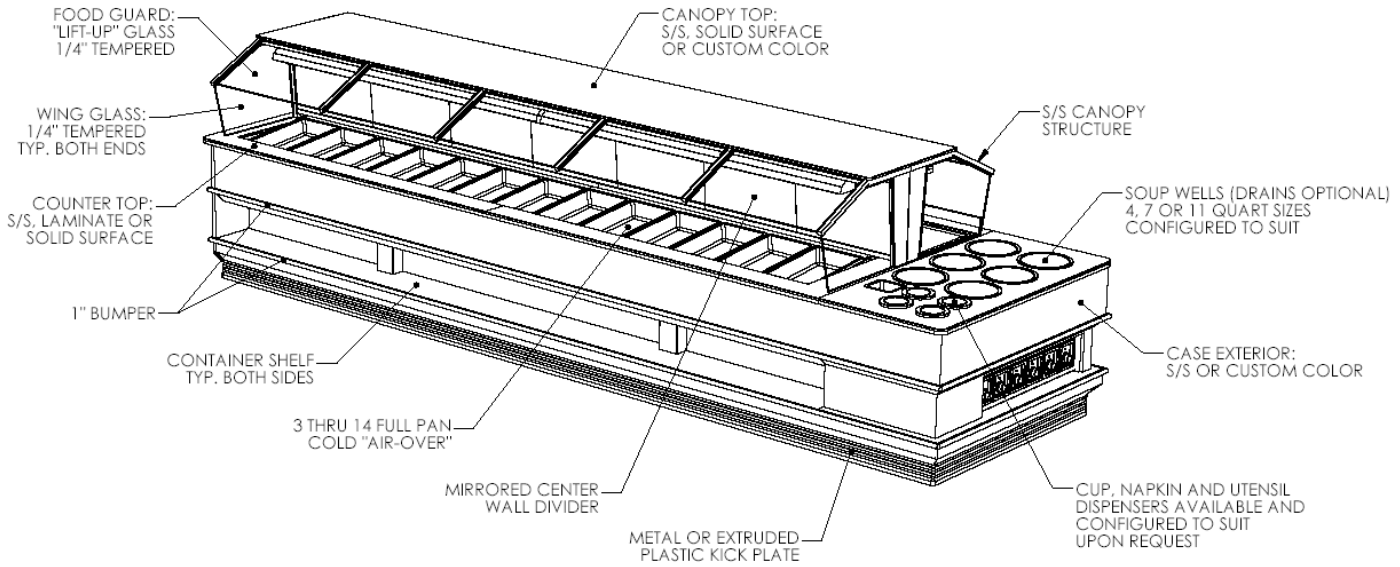

WSB-2-HC
(ANGLED PANS SHOWN)



specialty
fabricators

118 meany road
wrightstown, nj 08562
www.specialtyfabricators.com
609-758-6995

These Merchandisers are designed for use in stores where temperatures and humidity do not exceed 75°F and 55% R.H. (We reserve the right to change or revise specifications and product design in connection with any feature of our products. Such changes do not entitle the buyer to corresponding changes, improvements, additions, or replacement of equipment Previously sold or shipped.)

Hot Food Display Merchandiser

Applications:

- Hot Food

Features

- Customized exterior to fit store décor.
- Lift-up tempered glass food guard.
- Custom lengths and features available upon request.

Options:

- Alto Shaam
- Henny Penny
- Stainless steel countertop.
- Solid surface countertop.
- 1", 2" or 3" cart guard bumper.
- Container shelf.
- Overhead heat lamps.
- Heated shelf top.
- Soup wells.
- Rear sliding doors.
- Dry rear storage.
- Controls on front or rear of case.

Custom designed to meet your specific needs:

- Computer 3D Solid Modeled.
- Computer controlled parts production.
- The possibilities are endless!



These Merchandisers are designed for use in stores where temperatures and humidity do not exceed 75°F and 55% R.H. (We reserve the right to change or revise specifications and product design in connection with any feature of our products. Such changes do not entitle the buyer to corresponding changes, improvements, additions, or replacement of equipment Previously sold or shipped.)

specialty
fabricators

118 meany road
wrightstown, nj 08562
www.specialtyfabricators.com
609-758-6995

Pickle Bar Merchandiser

Applications:

- Pickle
- Impulse

Features

- Customized exterior to fit store décor.
- “Flip-up” Plexiglas lids.
- Custom lengths and features

Options:

- Stainless steel countertop.
- Solid surface countertop.
- 1”, 2” or 3” cart guard bumper.
- Container shelf.
- Dry front or rear storage.

Custom designed to meet your specific needs:

- Computer 3D Solid Modeled.
- Computer controlled parts production.
- The possibilities are endless!



These Merchandisers are designed for use in stores where temperatures and humidity do not exceed 75°F and 55% R.H. (We reserve the right to change or revise specifications and product design in connection with any feature of our products. Such changes do not entitle the buyer to corresponding changes, improvements, additions, or replacement of equipment Previously sold or shipped.)

specialty
fabricators

118 meany road
wrightstown, nj 08562
www.specialtyfabricators.com
609-758-6995

SHB "Flat Front" Single sided Hot Food Bar

Applications:

- Hot Food

Features

- 1 full pan width.
- Customized exterior to fit store décor.
- Radial-top tempered glass food guard.
- Stainless steel food guard poles.
- Stainless steel countertops.
- 1" or 3" cart guard bumper.
- Custom lengths, depths and features available upon request.

Options:

- Stone countertop.
- "Euro" pedestal kick panel. (shown)
- 3/8" tempered food guard shelf. (serv. side)
- Heated shelf top.
- Soup wells
- Rear sliding doors.
- Dry rear storage.
- Controls on front or rear of case.

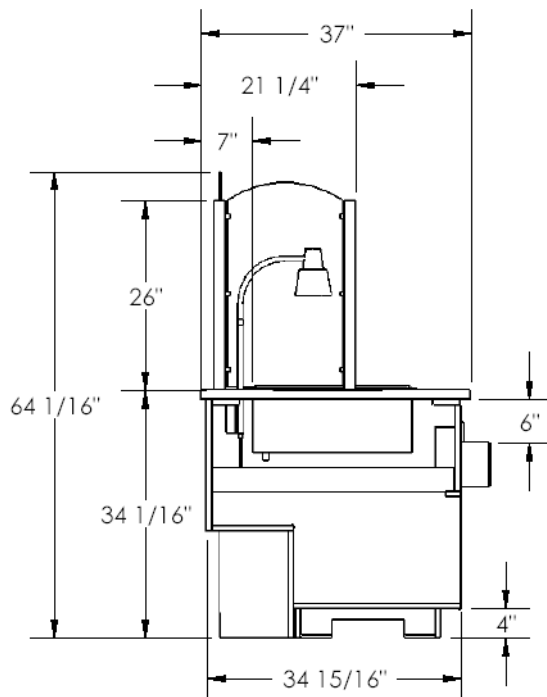

These Merchandisers are designed for use in stores where temperatures and humidity do not exceed 75°F and 55% R.H. (We reserve the right to change or revise specifications and product design in connection with any feature of our products. Such changes do not entitle the buyer to corresponding changes, improvements, additions, or replacement of equipment Previously sold or shipped.)

specialty
fabricators

118 meany road
wrightstown, nj 08562
www.specialtyfabricators.com
609-758-6995

SHB Single sided Hot Food Bar

Applications:

- Hot Food

Features

- Available in 3 thru 14 pan lengths.
- 1 full pan width.
- Customized exterior to fit store décor.
- Lift-up tempered glass food guard.
- Stainless steel canopy structure.
- Overhead heat.
- Solid surface countertops.
- Custom color canopy top.
- Container shelf.
- 1" and 3" cart guard bumper.
- Electronic Ballasts
- Custom lengths, depths and features

Options:

- Stainless steel countertop.
- Stainless steel or solid surface canopy top.
- Solid flat front
- Overhead heat lamps.
- Heated shelf top.
- Soup wells
- Rear sliding doors.
- Dry rear storage.
- Controls on front or rear of case.

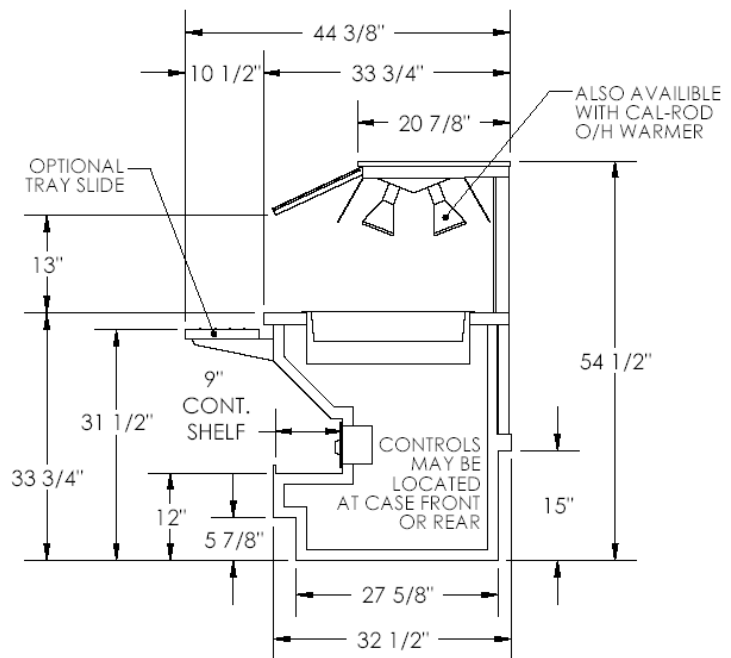

These Merchandisers are designed for use in stores where temperatures and humidity do not exceed 75°F and 55% R.H. (We reserve the right to change or revise specifications and product design in connection with any feature of our products. Such changes do not entitle the buyer to corresponding changes, improvements, additions, or replacement of equipment Previously sold or shipped.)

specialty
fabricators

118 meany road
wrightstown, nj 08562
www.specialtyfabricators.com
609-758-6995

WHB Hot Wing Bar

Applications:

- Hot Food

Features

- 3 pan length
- 1 full pan width.
- Customized exterior to fit store décor.
- Lift-up tempered glass food guard.
- Stainless steel canopy structure.
- Overhead heat.
- Solid surface countertops.
- Custom color canopy top.
- Container shelf.
- 1" and 3" cart guard bumper.
- Custom lengths, depths and features

Options:

- Available in 4, 5 & 6 pan lengths
- Stainless steel countertop.
- Stainless steel or solid surface canopy top.
- Solid flat front
- Overhead heat lamps.
- Controls on front or rear of case.

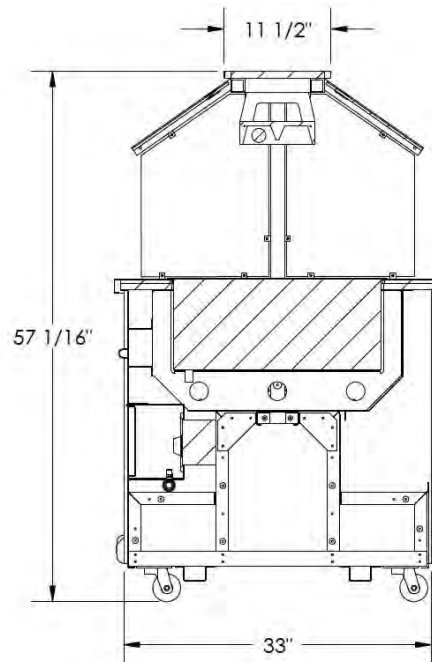

These Merchandisers are designed for use in stores where temperatures and humidity do not exceed 75°F and 55% R.H. (We reserve the right to change or revise specifications and product design in connection with any feature of our products. Such changes do not entitle the buyer to corresponding changes, improvements, additions, or replacement of equipment Previously sold or shipped.)

specialty
fabricators

118 meany road
wrightstown, nj 08562
www.specialtyfabricators.com
609-758-6995

WHB Walk-Around Hot Food Bar

Applications:

- Hot Food

Features

- 2 full pan or surface-top warmer width.
- Customized exterior to fit store décor.
- Lift-up tempered glass food guard.
- Stainless steel canopy structure.
- Overhead heat.
- Stainless steel countertop.
- Custom color canopy top.
- Container shelf.
- 1" and 3" cart guard bumper.
- Solar digital thermometer.
- Electronic Ballasts
- Custom lengths, depths and features

Options:

- Solid surface countertops.
- Stainless steel or solid surface canopy top.
- Soup Wells
- Solid flat front
- Overhead heat lamps.
- Rear sliding doors.
- Dry rear storage.
- Controls on front or rear of case.



These Merchandisers are designed for use in stores where temperatures and humidity do not exceed 75°F and 55% R.H. (We reserve the right to change or revise specifications and product design in connection with any feature of our products. Such changes do not entitle the buyer to corresponding changes, improvements, additions, or replacement of equipment Previously sold or shipped.)

specialty
fabricators

118 meany road
wrightstown, nj 08562
www.specialtyfabricators.com
609-758-6995

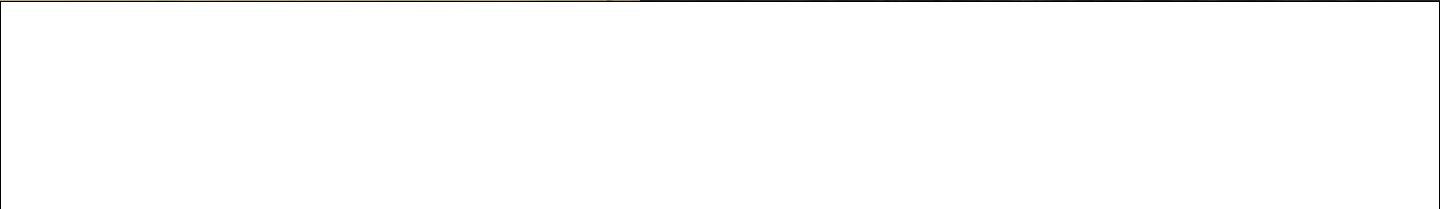

Customized Soup Bar Merchandisers

Applications:

- Soup
- Hot Food

Features

- Customized exterior to fit store décor.
- Choose from 4qt., 7qt. or 11qt. soup wells.
- Stainless steel canopy structure
- Solid surface countertops
- 1" and 3" cart guard bumper
- Electronic Ballasts
- Custom lengths, depths and features

Options:

- Stainless steel countertop.
- Custom color, solid surface or Stainless steel canopy top.
- Lift-up tempered glass food guard
- Overhead heat lamps.
- Dry rear storage.
- Controls on front or rear of case.



Custom designed to meet your specific needs:

- Computer 3D Solid Modeled.
- Computer controlled parts production.
- The possibilities are endless!



These Merchandisers are designed for use in stores where temperatures and humidity do not exceed 75°F and 55% R.H. (We reserve the right to change or revise specifications and product design in connection with any feature of our products. Such changes do not entitle the buyer to corresponding changes, improvements, additions, or replacement of equipment Previously sold or shipped.)

specialty
fabricators

118 meany road
wrightstown, nj 08562
www.specialtyfabricators.com
609-758-6995

ICE OYSTER BAR

Applications:

- Seafood
- Impulse
- Beverage

Features

- Available in 4', 6', 8', 10' and 12' lengths.
- Exterior and interior of case is available in stainless or custom color.
- Customized exterior to fit store décor.
- Stainless steel tank interior.
- 1" cart guard bumper
- Solid contour end panels to suit profile of parent case

Options:

- Custom lengths, depths and features available upon request.

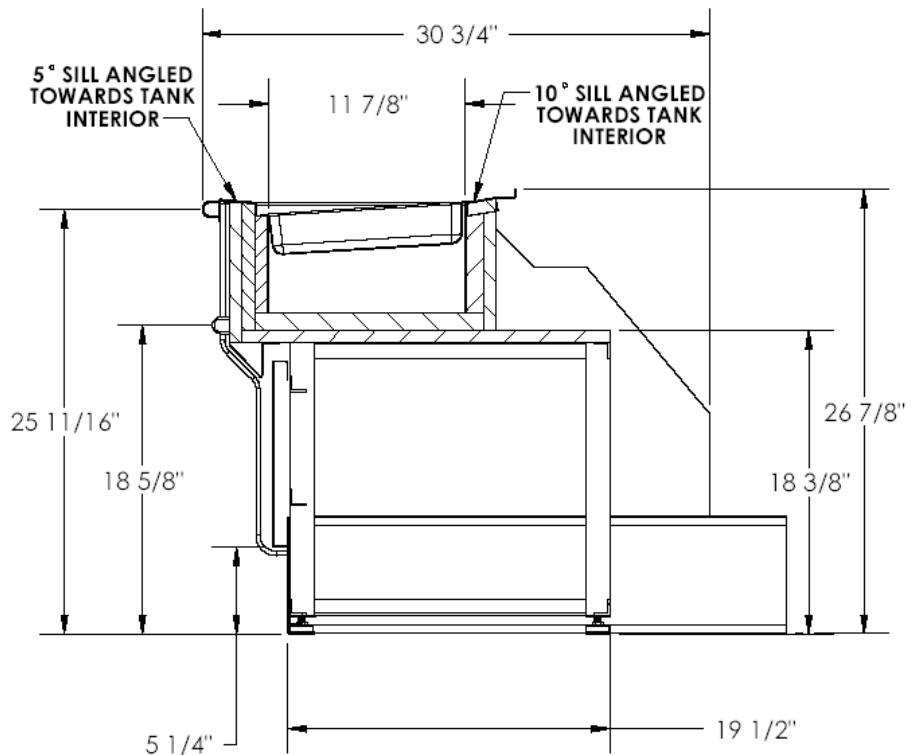

These Merchandisers are designed for use in stores where temperatures and humidity do not exceed 75°F and 55% R.H. (We reserve the right to change or revise specifications and product design in connection with any feature of our products. Such changes do not entitle the buyer to corresponding changes, improvements, additions, or replacement of equipment Previously sold or shipped.)

specialty
fabricators

118 meany road
wrightstown, nj 08562
www.specialtyfabricators.com
609-758-6995

BAKERY BWC

Applications:

- Bagels
- Bread/Rolls
- Doughnuts
- Muffins
- Cookies

Features

- Customized exterior to fit store décor.
- Tempered glass swing or sliding doors.
- Custom exterior finish.
- Solid surface countertops
- 1" and 3" cart guard bumper
- Electronic Ballasts
- Custom lengths, depths and features available upon request.



These Merchandisers are designed for use in stores where temperatures and humidity do not exceed 75°F and 55% R.H. (We reserve the right to change or revise specifications and product design in connection with any feature of our products. Such changes do not entitle the buyer to corresponding changes, improvements, additions, or replacement of equipment Previously sold or shipped.)

specialty
fabricators

118 meany road
wrightstown, nj 08562
www.specialtyfabricators.com
609-758-6995

BWC-77

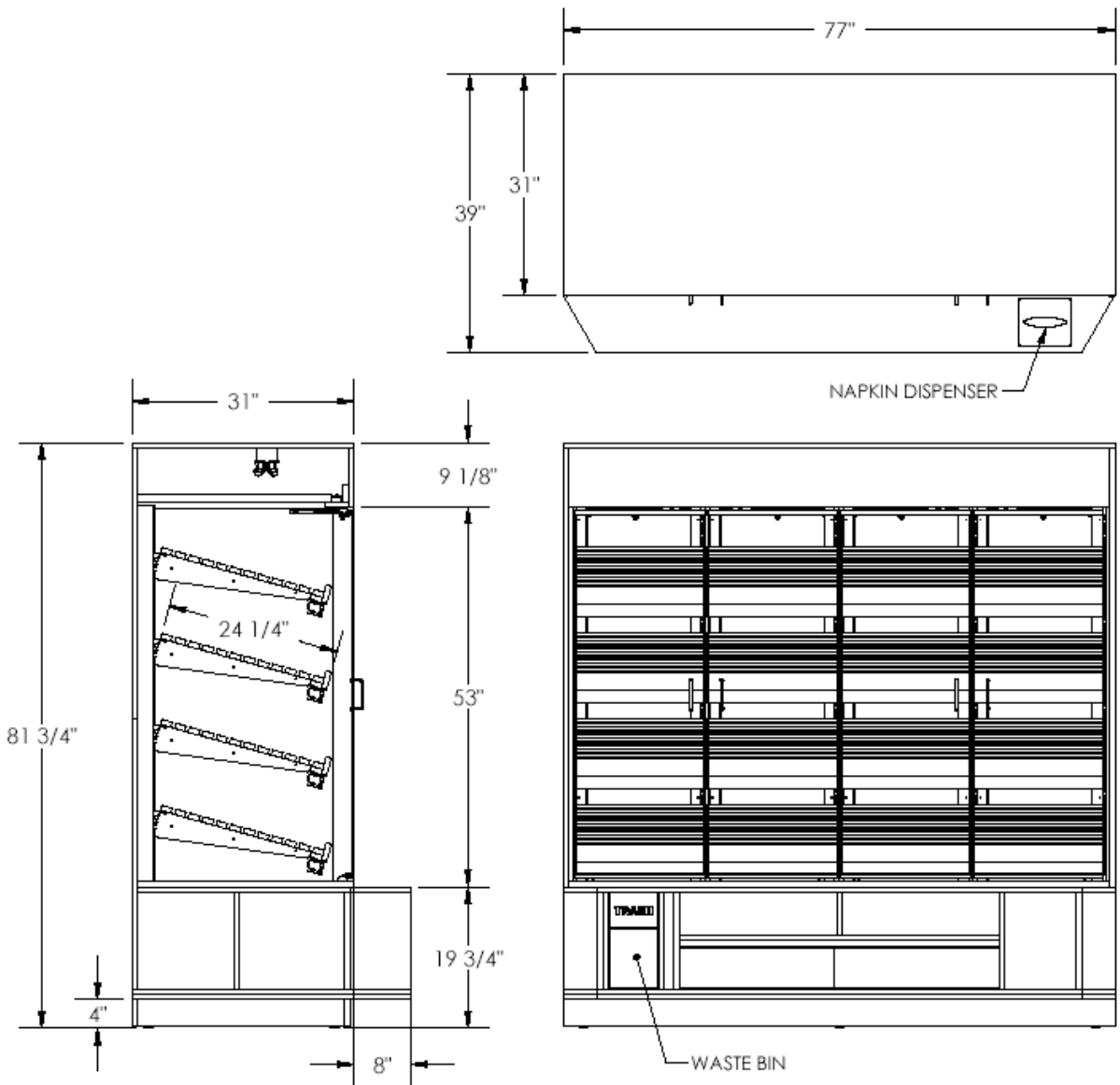

These Merchandisers are designed for use in stores where temperatures and humidity do not exceed 75°F and 55% R.H. (We reserve the right to change or revise specifications and product design in connection with any feature of our products. Such changes do not entitle the buyer to corresponding changes, improvements, additions, or replacement of equipment Previously sold or shipped.)

specialty
fabricators

118 meany road
wrightstown, nj 08562
www.specialtyfabricators.com
609-758-6995

Custom Mill Work

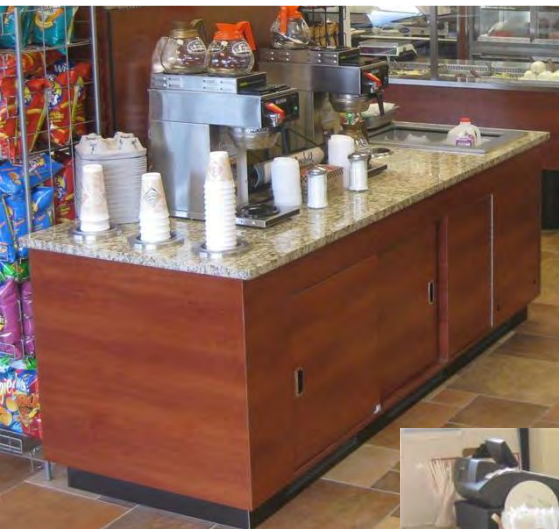

specialty
fabricators

118 meany road
wrightstown, nj 08562
www.specialtyfabricators.com
609-758-6995

These Merchandisers are designed for use in stores where temperatures and humidity do not exceed 75°F and 55% R.H. (We reserve the right to change or revise specifications and product design in connection with any feature of our products. Such changes do not entitle the buyer to corresponding changes, improvements, additions, or replacement of equipment Previously sold or shipped.)